

DOT LINE SUSPENSION

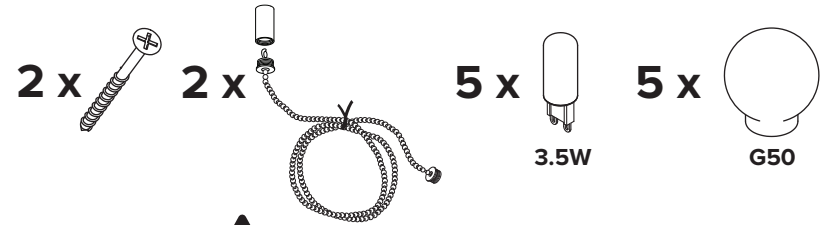

- To be installed by an electrician to an electrical box
- Use appropriate screws and anchors where necessary
- Wear enclosed gloves when handling lamp
- Handle materials with care. Please consult lamp maintenance sheet on our web site
- Should be used exclusively as a lamp and not as a shelving, display or hanging uni

lamp weight **11 lbs.**

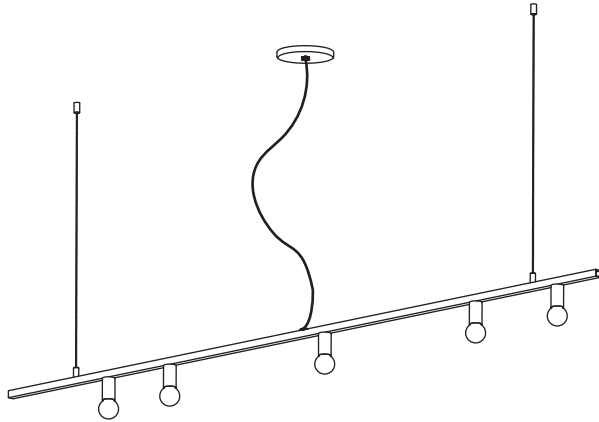
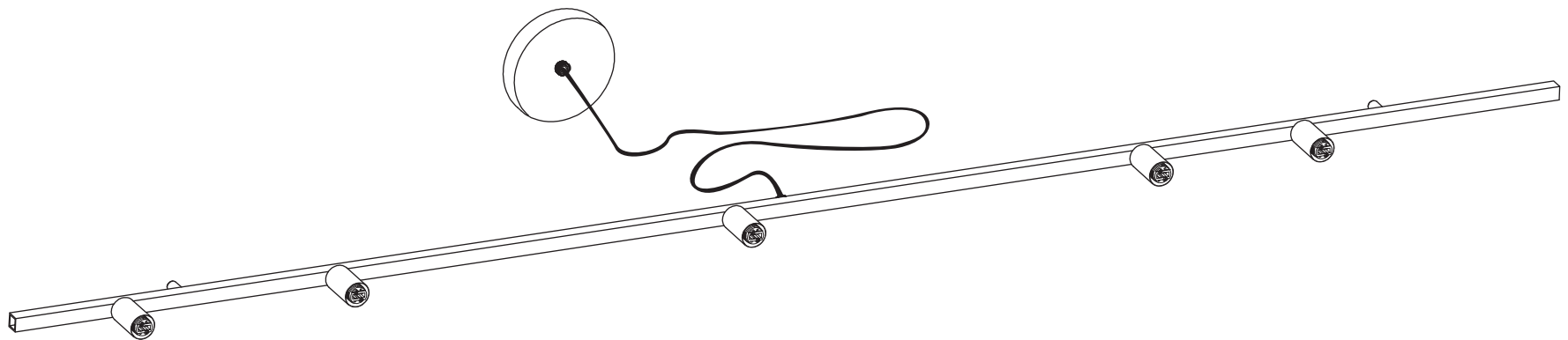

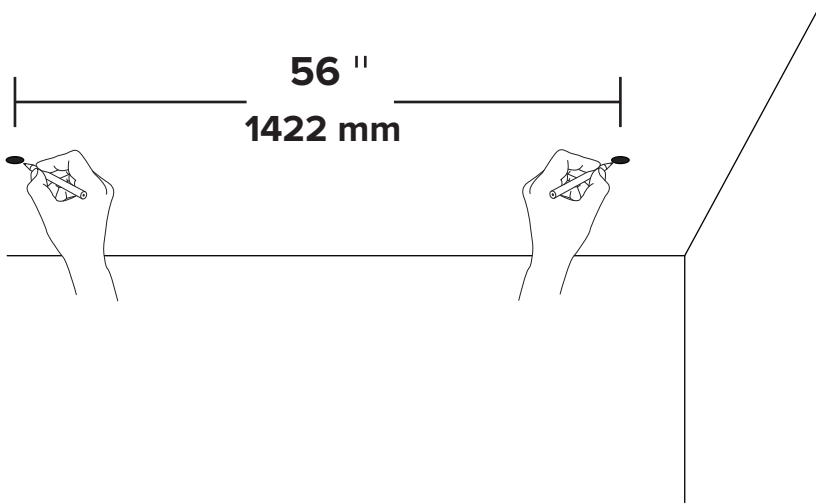

1

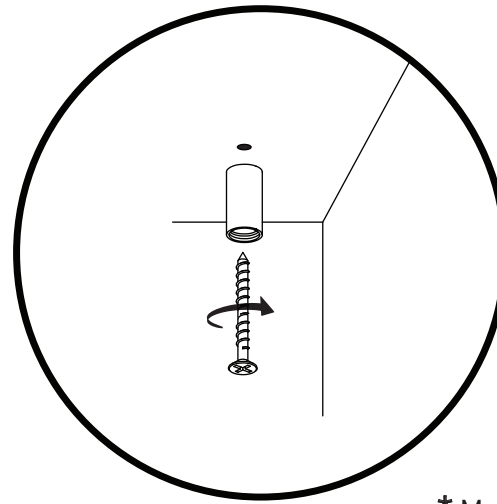

2

* Make sure to use appropriate anchors

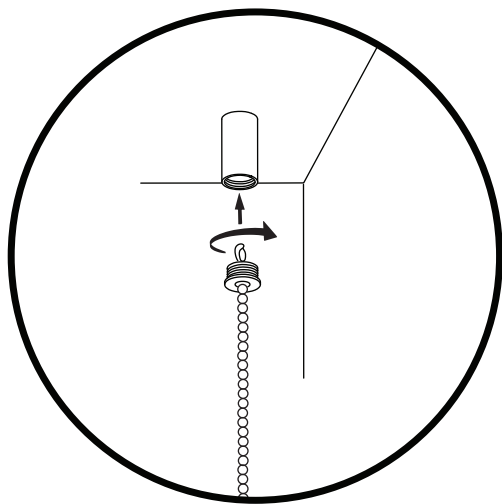

3

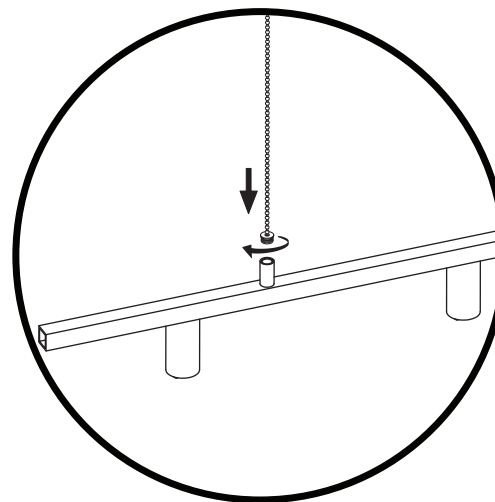

4

Do not install at less than 4" from the ceiling

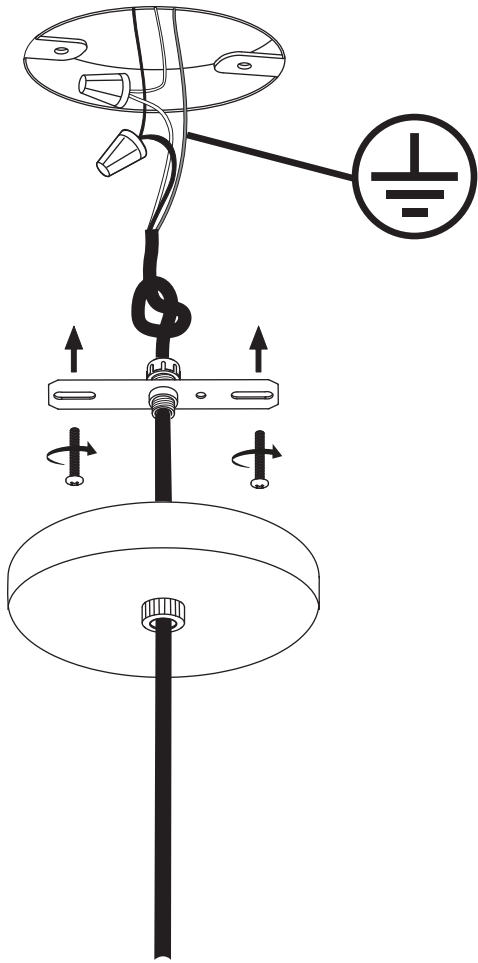

5

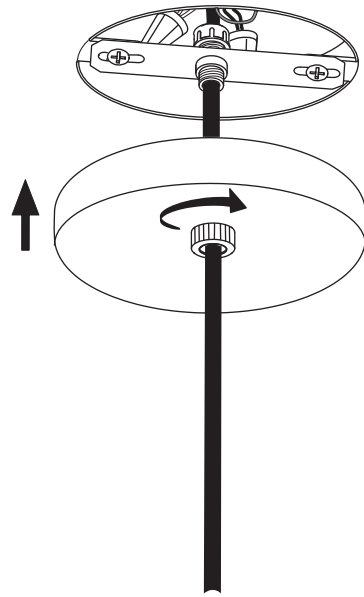

6

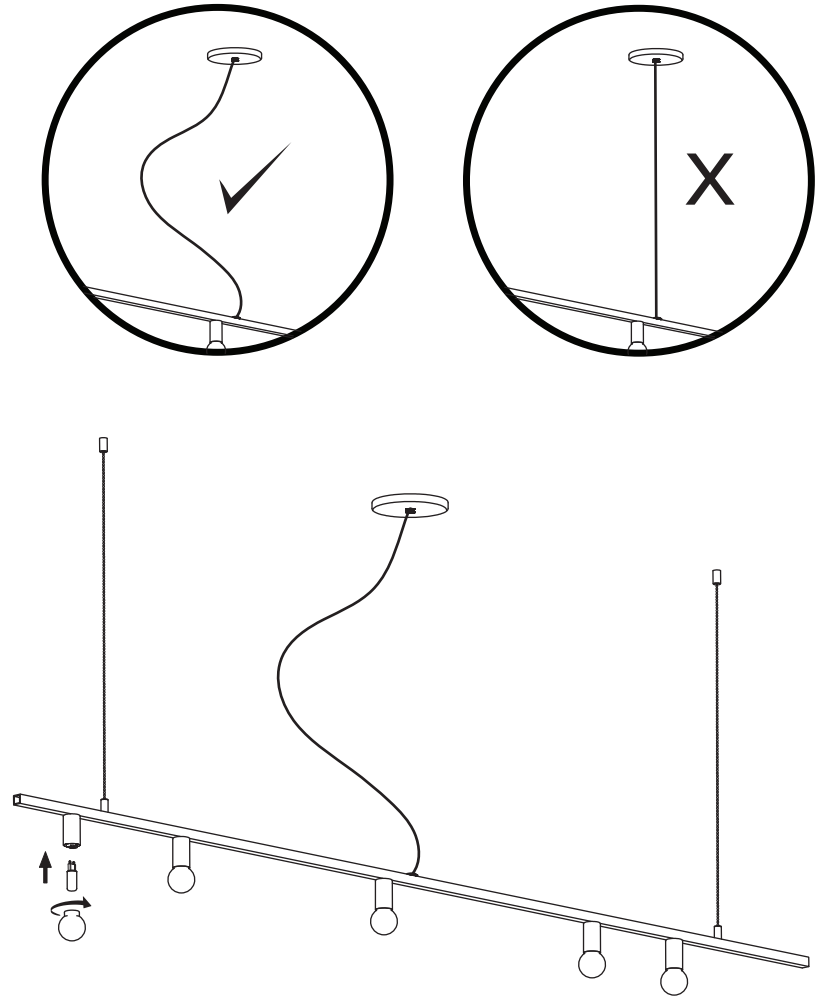

7