

SAINTE



WARNING - ACRYLIC PRODUCT **IMPORTANT NOTICE**

Take extra care when handling or moving the acrylic shade of the luminaire. Avoid touching it with any tools and keep away from any hard or abrasive surfaces (like rings, jewellery, watches, etc.). The edges and corners are especially fragile.

Keep the acrylic clean and wear gloves at all times. Do not put hands inside the acrylic body unnecessarily. This will allow for less cleaning and less chance to damage the acrylic.

Read and follow all steps carefully allowing the appropriate time for each step. Rushing the installation may cause accidents or damage.

**NEVER TURN ON POWER SUPPLY
UNTIL CONNECTIONS AND
INSTALLATION ARE COMPLETED.
DOING OTHERWISE COULD BE
HARMFUL TO YOUR LUMINAIRE.**



- Please read entire manual before installation
- To be installed by an electrician to an electrical box
- Use appropriate screws and anchors where necessary
- Wear enclosed gloves when handling acrylic body
- Handle materials with care. Please consult lamp maintenance sheet on our web site



PLEASE NOTE

ALL SAINTE MODELS FOLLOW
THE SAME INSTALLATION PROCESS.

Each luminaire comes shipped in three boxes.

To protect the luminaire do not open the boxes until
the installation process requires it.

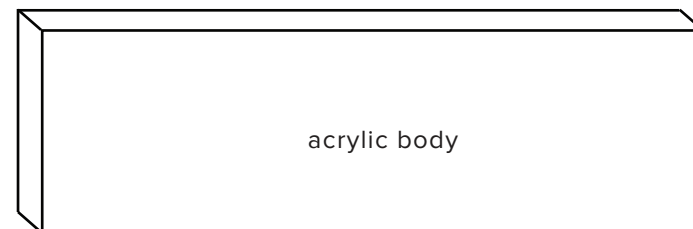
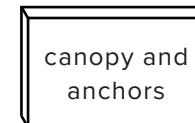

*One pair of scissors has been
provided for each order. If you
order several Saintes, only one
pair will be provided.

INSTALL CEILING ANCHORS

1

Determine the setup of your luminaire, either angled or parallel.

angled

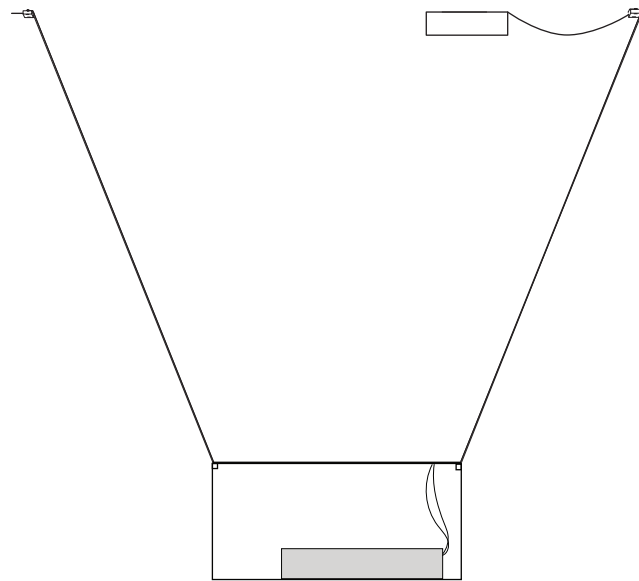

parallel



OR

Chose the placement of your canopy, either exterior or interior

exterior

interior

exterior

interior

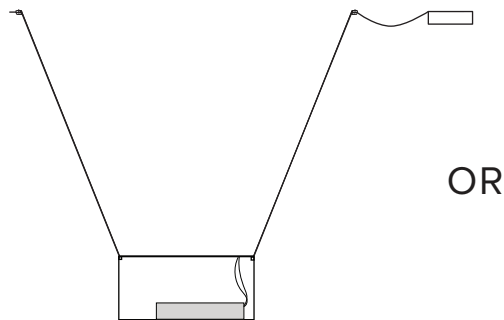

OR

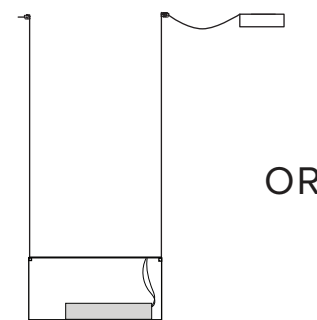
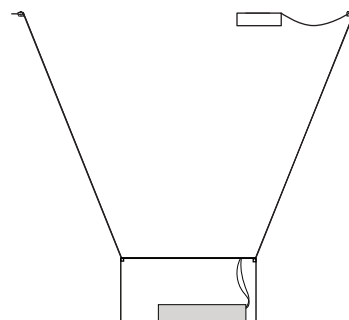

OR

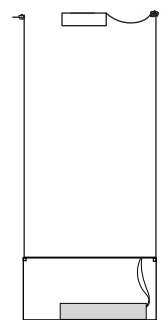

2

Mark your **X** dimension.

The distance is from center to center of each anchor.

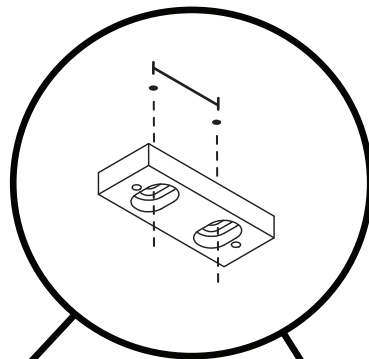

Use your anchor plate as a guide to make your marks.

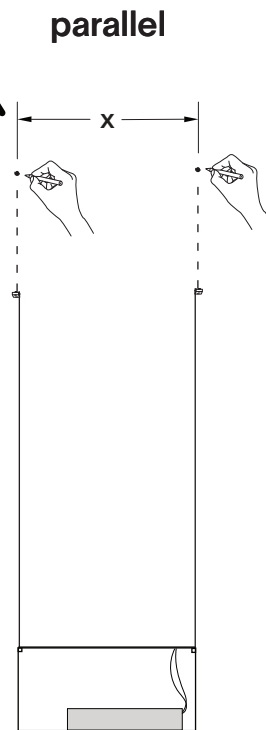
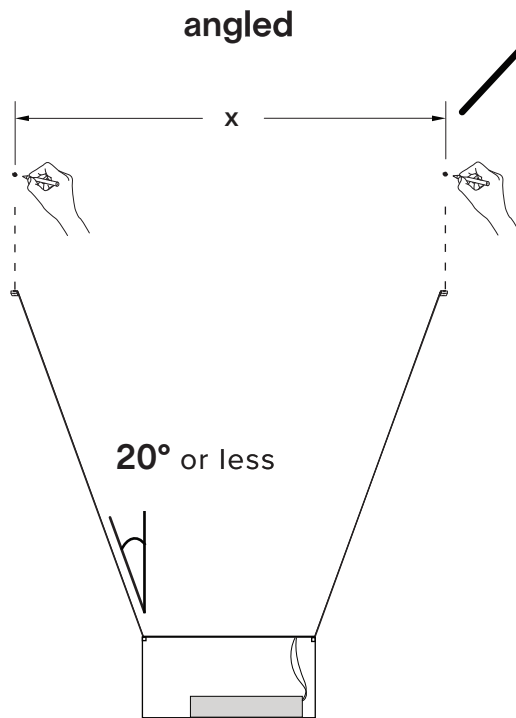

Choose your distance **X** for angled as long as it is less than 20°.

Note that dimensions vary for interior or exterior canopy.



EXTERIOR CANOPY

- X = SAINTE 21** 31 ³/₈" / 79.7 cm
- SAINTE 22** 19 ⁷/₈" / 50.5 cm
- SAINTE 23** 16 ³/₈" / 41.6 cm
- SAINTE 24** 9 ³/₈" / 23.8 cm
- SAINTE 25** 23 ⁷/₈" / 60.6 cm
- SAINTE 26** 49 ⁵/₈" / 126 cm
- SAINTE 27** 25 ⁵/₈" / 65.1 cm
- SAINTE 28** 21 ⁵/₈" / 54.9 cm
- SAINTE 29** 28 ⁵/₈" / 72.7 cm

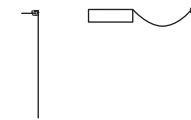

INTERIOR CANOPY

- X = SAINTE 21** 30 ¹/₄" / 76.8 cm
- SAINTE 22** 18 ³/₄" / 47.6 cm
- SAINTE 23** 15 ¹/₄" / 38.7 cm
- SAINTE 24** not possible for this model
- SAINTE 25** 22 ³/₄" / 57.8 cm
- SAINTE 26** 48 ¹/₄" / 122.6 cm
- SAINTE 27** 24 ¹/₄" / 61.6 cm
- SAINTE 28** 20 ¹/₄" / 51.4 cm
- SAINTE 29** 27 ¹/₄" / 69.2 cm

3

Install the aluminum ceiling anchors.

*** Use appropriate mounting hardware (not provided) for the weight of your luminaire**

SAINTE 21 9.1 lb / 4.1 kg

SAINTE 22 13.8 lb / 6.3 kg

SAINTE 23 11.7 lb / 7.3 kg

SAINTE 24 4.5 lb / 2 kg

SAINTE 25 9.6 lb / 4.4 kg

SAINTE 26 26.2 lb / 11.8 kg

SAINTE 27 25.4 lb / 11.4 kg

SAINTE 28 16.7 lb / 7.6 kg

SAINTE 29 19 lb / 8.6 kg

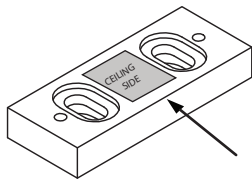

Note the ceiling side of the anchor is clearly labelled with a sticker.



Make sure screw heads are fully immersed into the holes.

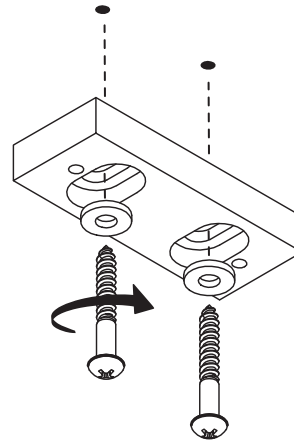

Assembly with NO.8 screws (or other) and washers (included)

OR

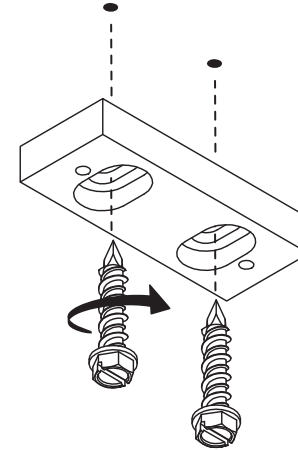

Assembly with Tapcon no washers required

4

Partially screw the top plate of the anchor to temporarily allow the ribbon to freely pass through.

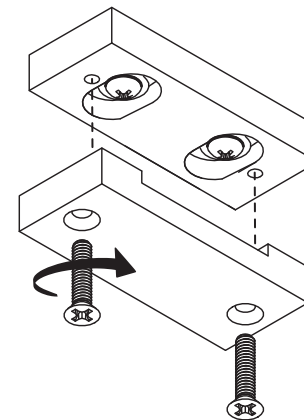

DETERMINE ORIENTATION OF THE ACRYLIC SHADE AND THE ELECTRICAL SIDE

5

The light block should be on the same side as your junction box

Choose the orientation for acrylic shades with different finishes on both sides.

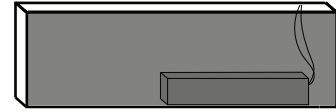

OR

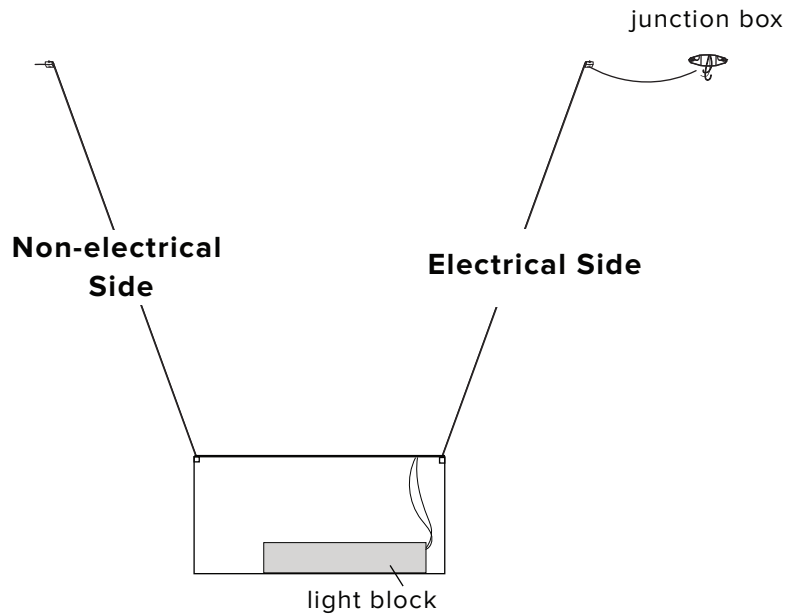
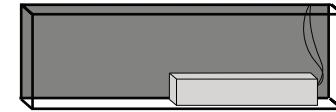

OR

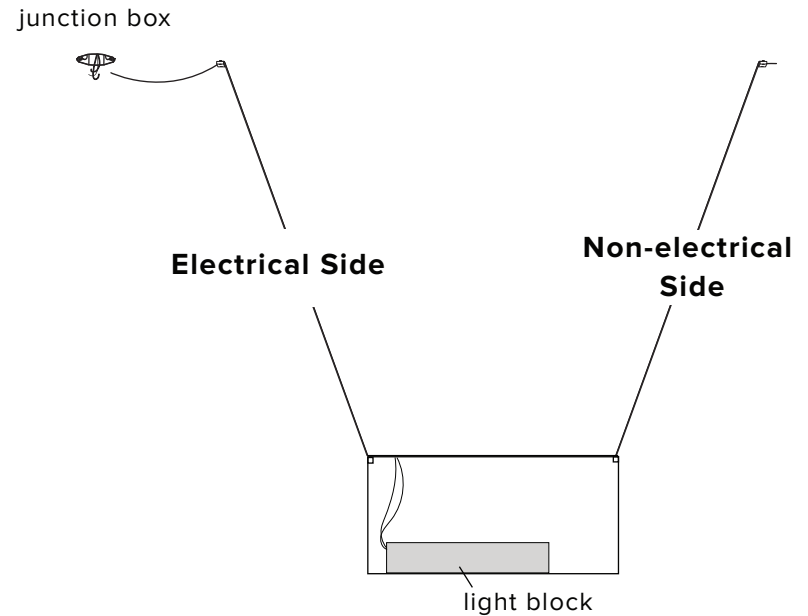

6

Place acrylic body on a flat, non abrasive surface. Undo twist ties and un-roll the ribbons.

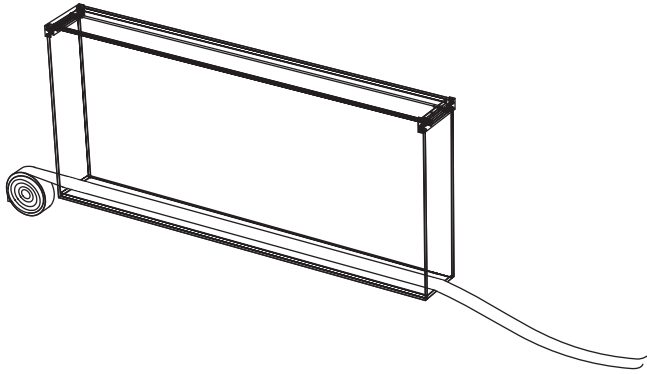

Pass both ribbons through the acrylic anchor system. Make sure there are no twists in the ribbon.

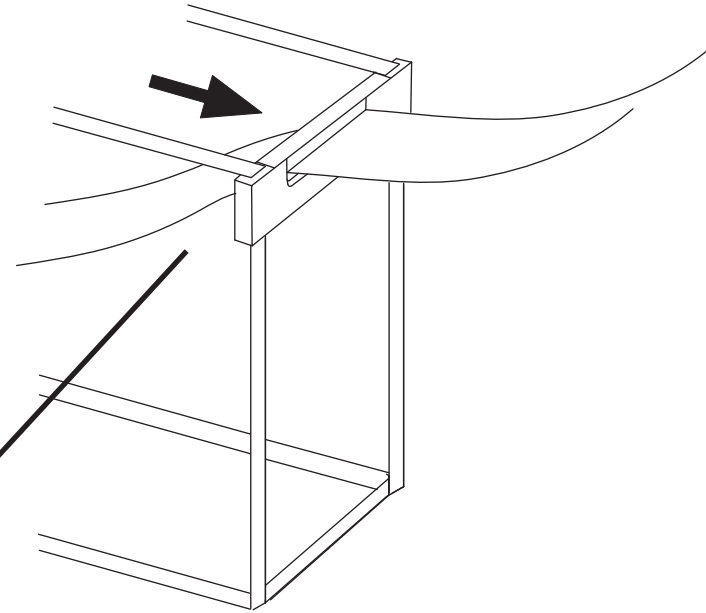
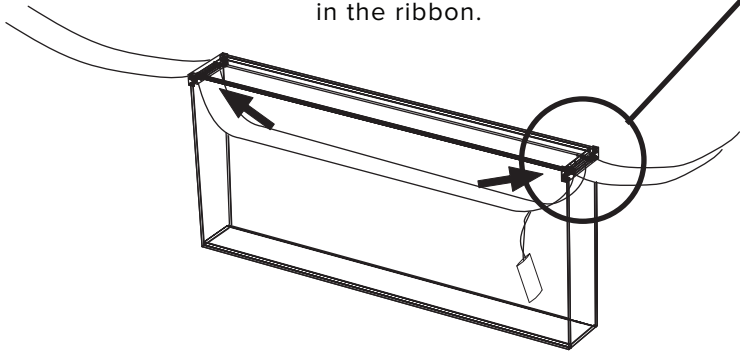

Pull ribbon until the acrylic shade is centered in between the two positioning threads. The wires should be approximately 2"/5cm from the edge of the acrylic.

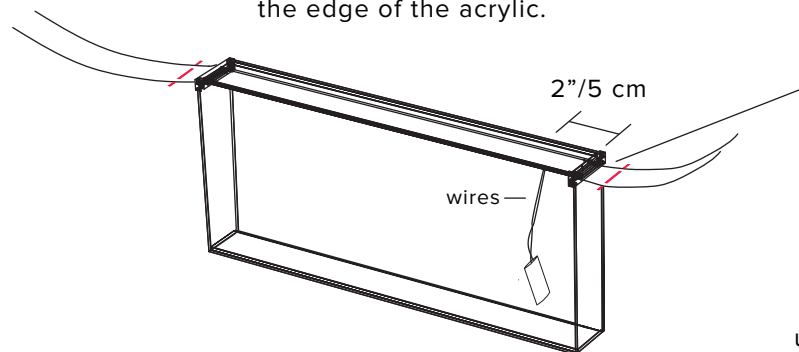

Positioning thread

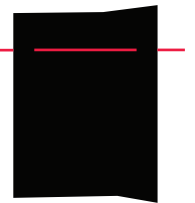

Do not remove positioning thread until the installation is complete.

INSTALL THE LUMINAIRE

7

Pass the ribbon through each ceiling anchor. Make sure to leave enough ribbon for connection on the electrical side. Tighten ceiling anchors when desired length is achieved.

Make sure there are no twists in the ribbon.



Non-electrical Side

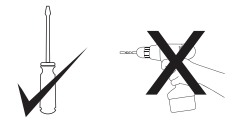
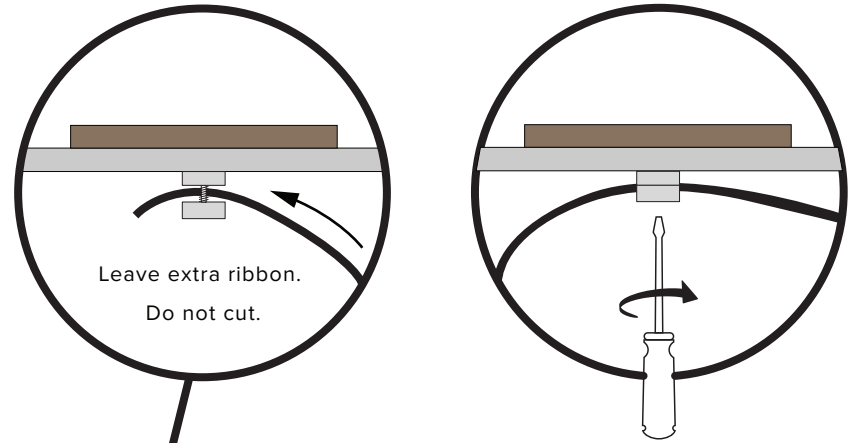
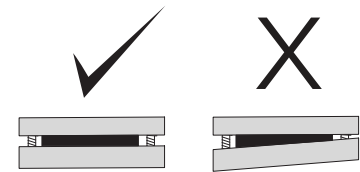

SCREW FIRMLY

8

Ensure that the acrylic body is level and centered in between the positioning threads. If needed, adjust height. Then remove positioning threads from the ribbon.

Make sure to not scratch or damage your acrylic shade.

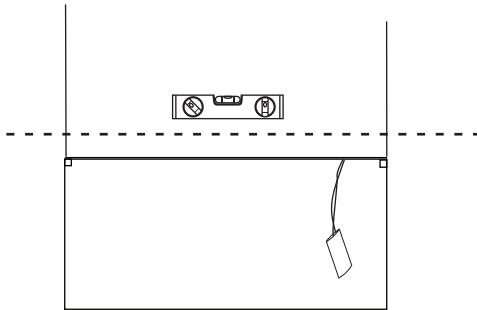

9

Insert light block into body and leave it sticking out 1" / 2.5 cm from the edge.

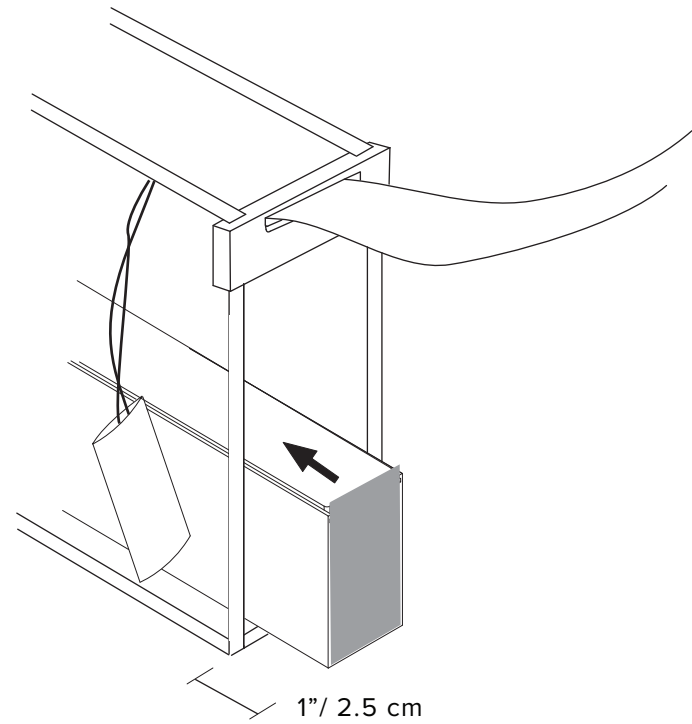

10

Remove protective tape.

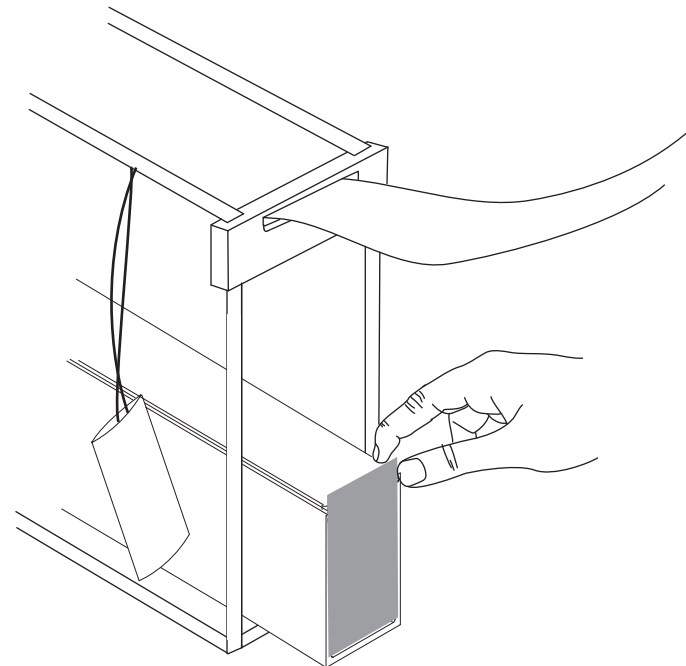

11

Remove end cap
from foam pouch.

Make connection
with quick connectors.

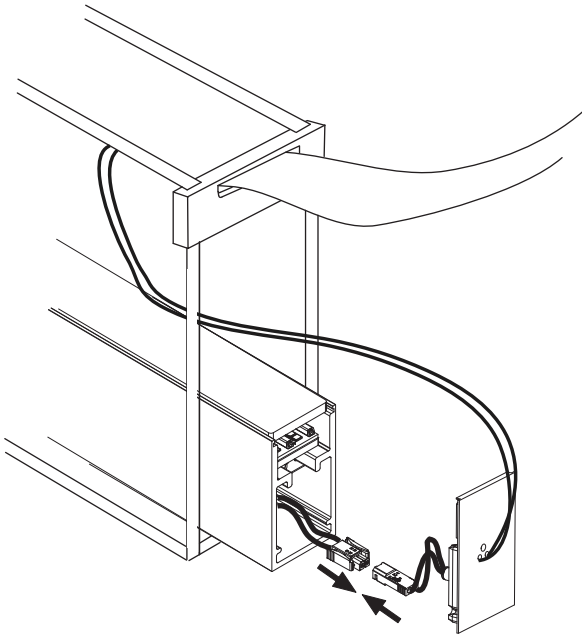

12

Carefully screw on
the endcap.

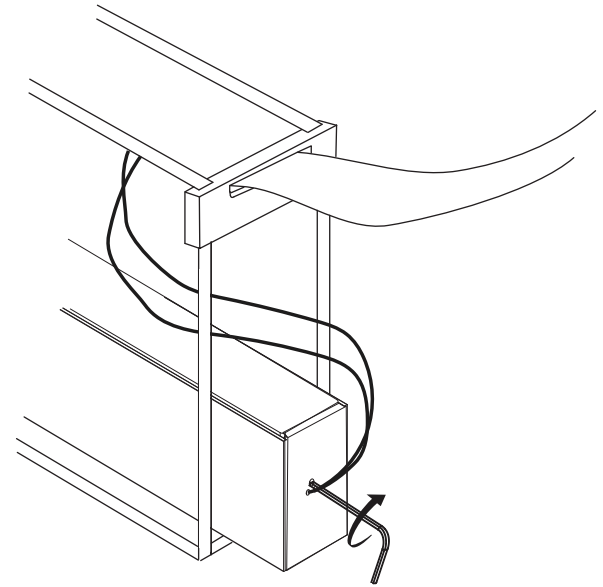

13

Carefully slide the light
block inside the body.

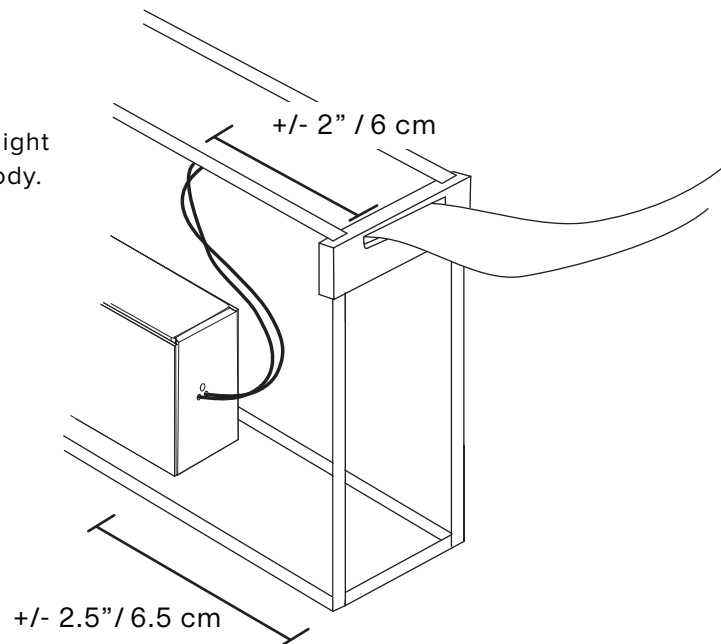

Make sure the wires do not stick out past the edge of the acrylic shade and that they sit properly.

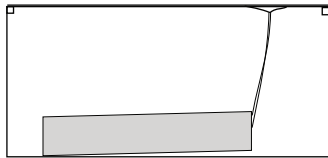
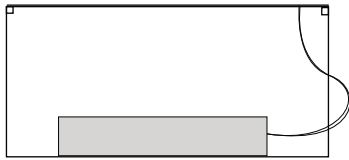
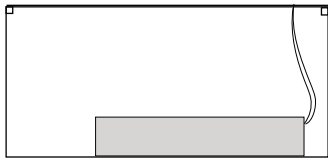

If your wires are too short or too long, unscrew end cap, loosen strain relief screws, pull wires out further while making sure the protective sleeve stays under the strain relief.

Pull out / push in extra wires

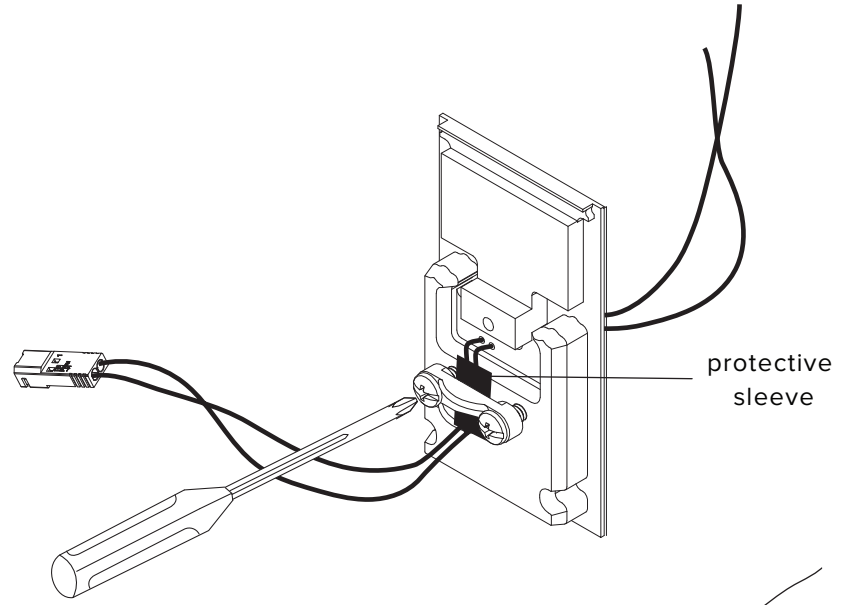

Retighten strain relief screws when desired length is reached..

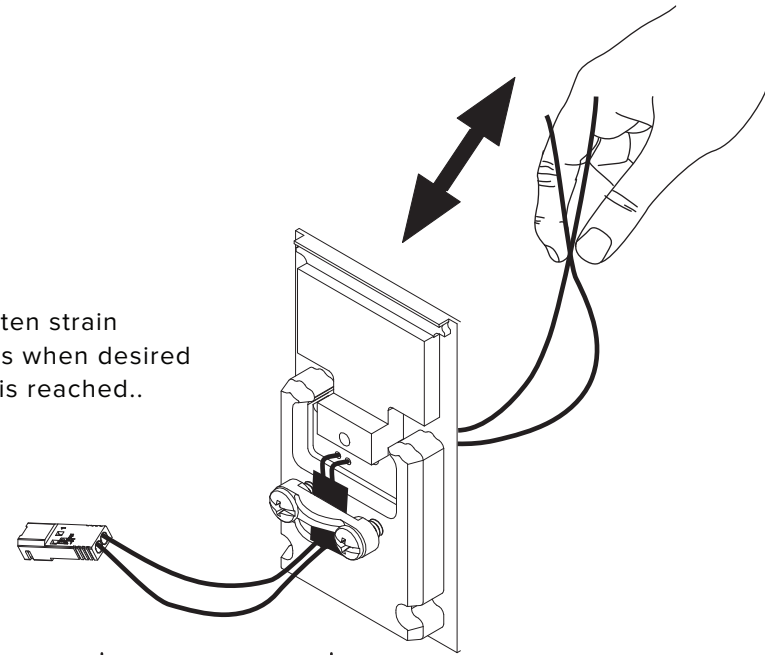

minimum 1-2" / 2.5-5cm

OPEN THE CANOPY

14

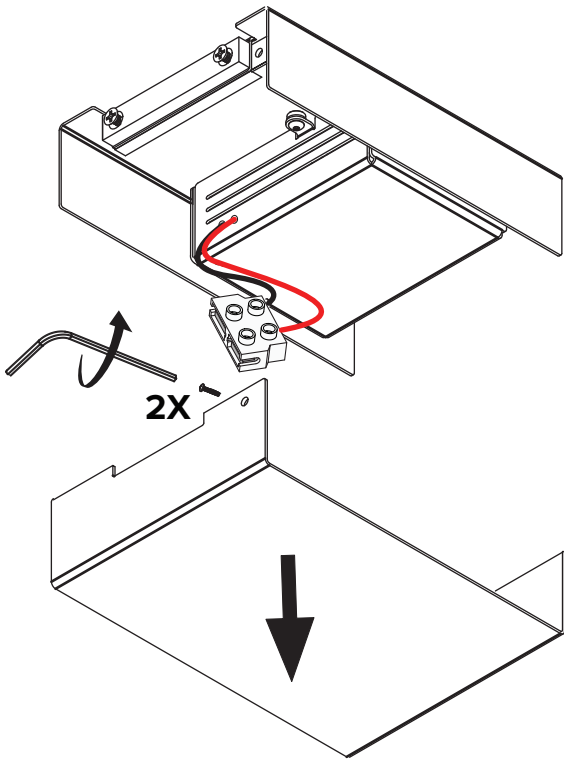

Remove the screws in the front and back of the canopy cover and lower it.

15

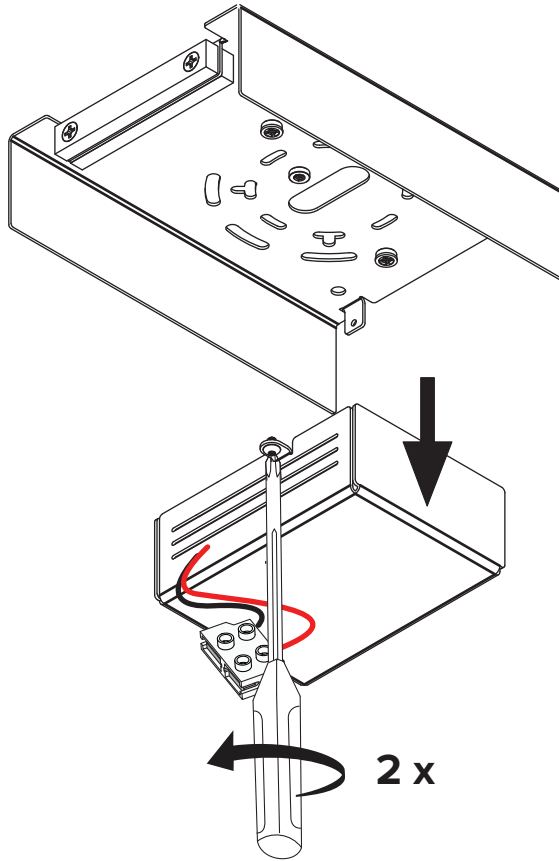

INSTALL EXTENSION HARNESS

16

Connect the provided extension harness to the junction box

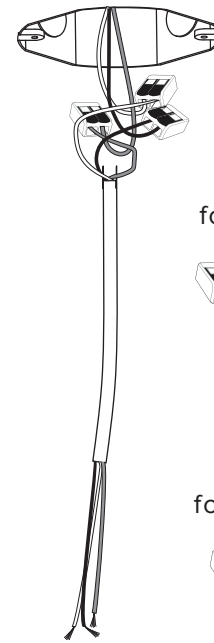

for 120 V wiring

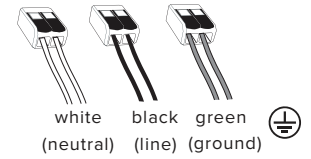

for 220-240 V wiring

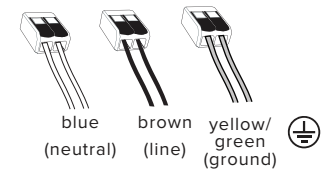

MOUNT CANOPY BRACKET

17

Ensure that the strain relief plate faces the lamp electrical side of the lamp ribbon.

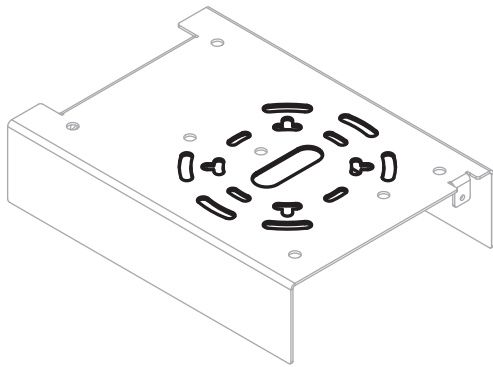

To junction box

*if the pattern does not fit your junction box, use the other installation method

OR

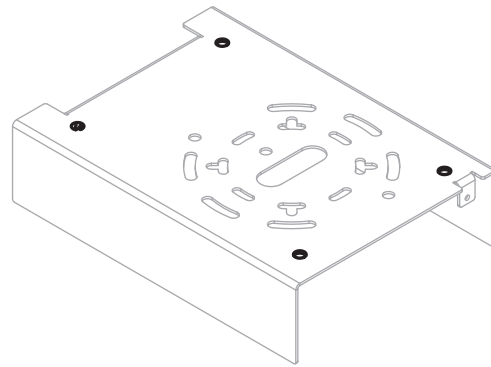

directly to the ceiling

*use appropriate anchors

Strain relief plate

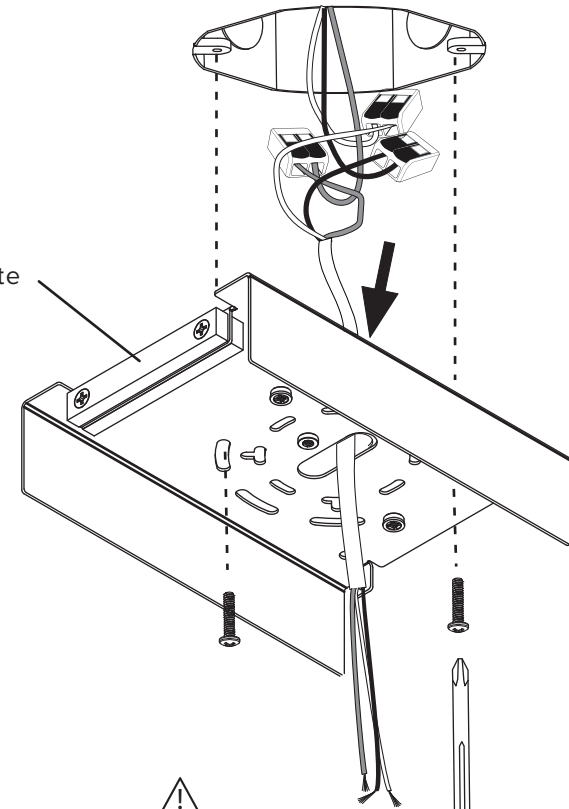

⚠
Ensure no wires are clipped or pinched during these steps.

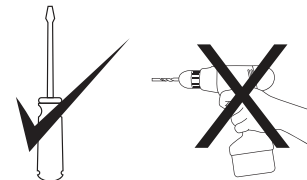

MAKE LINE/MAIN VOLTAGE CONNECTION TO ELECTRICAL BOX (AC)

18

Connect the extension harness to AC input wires of the driver and connect ground from bracket to the harness.

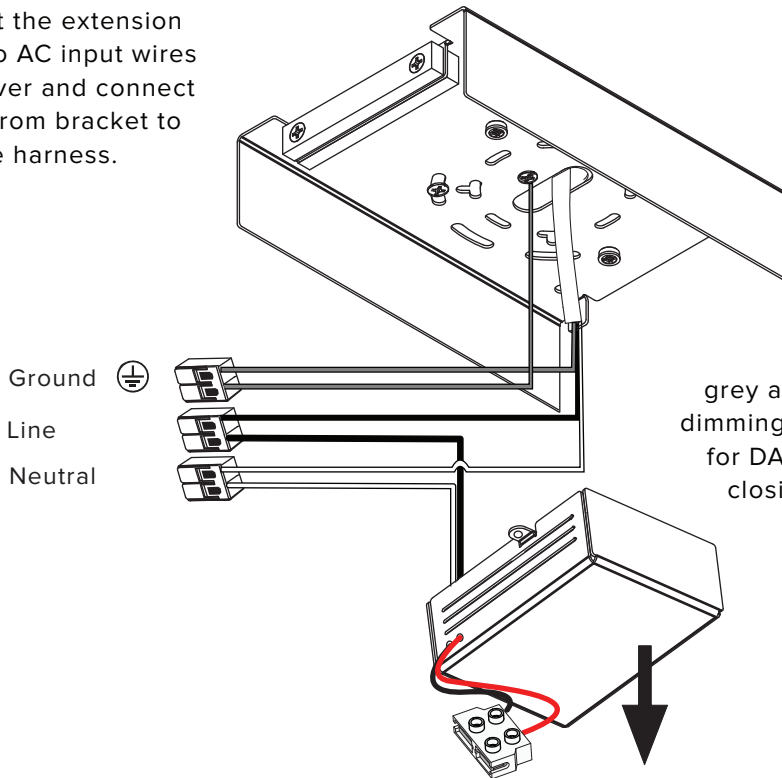

Ground 
Line
Neutral

If applicable, use grey and purple wires for 0-10V dimming circuit, or the orange wires for DALI dimming circuit before closing the driver enclosure.

19

Carefully close driver enclosure. It is held by two screws.

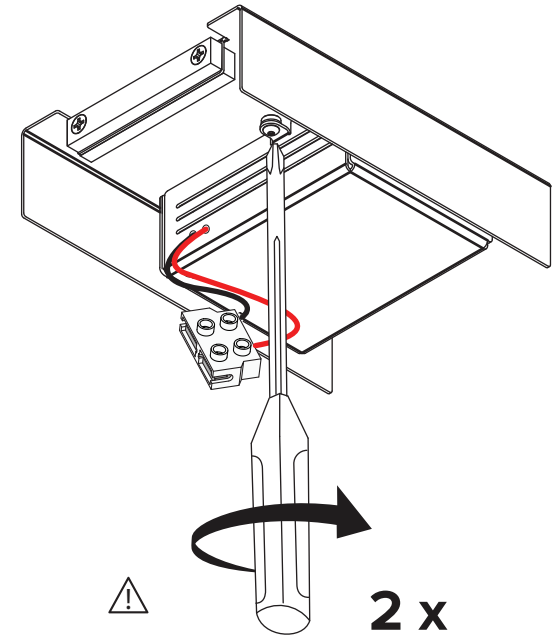

 Ensure no wires are damaged during these steps.

2 x

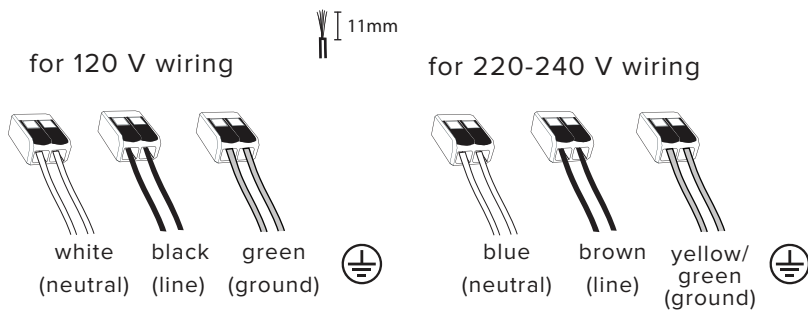

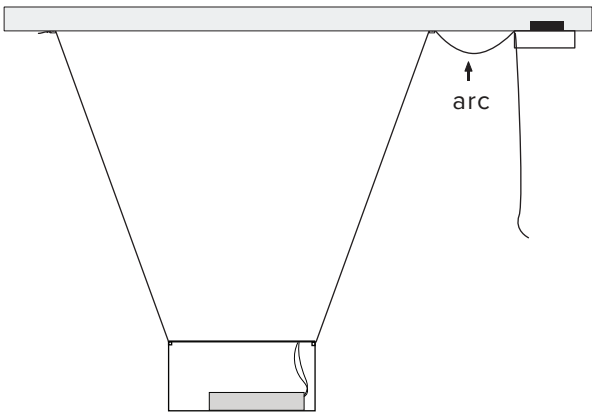
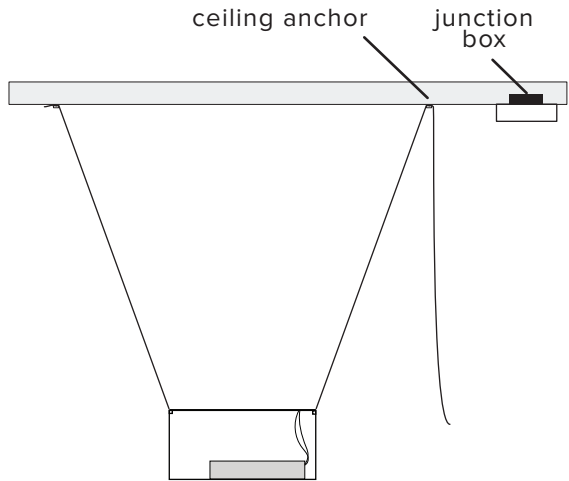

20

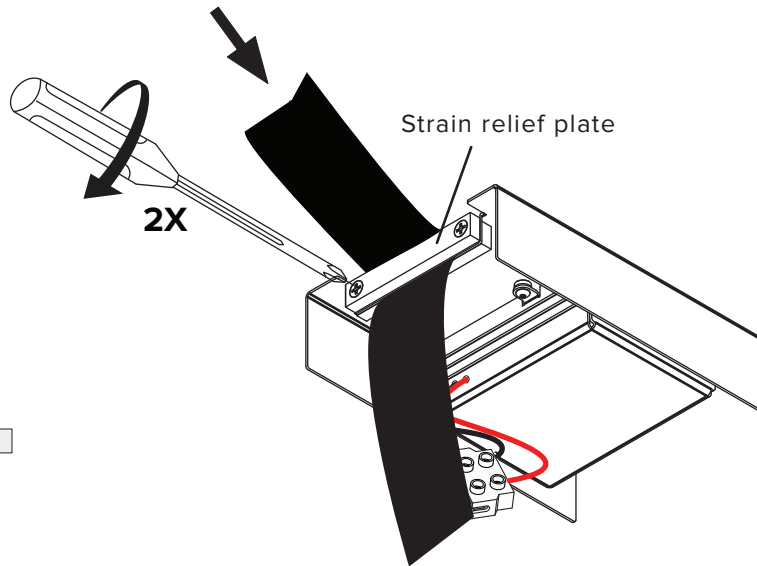

Screw gently but firmly by alternating between one screw and the other.

21

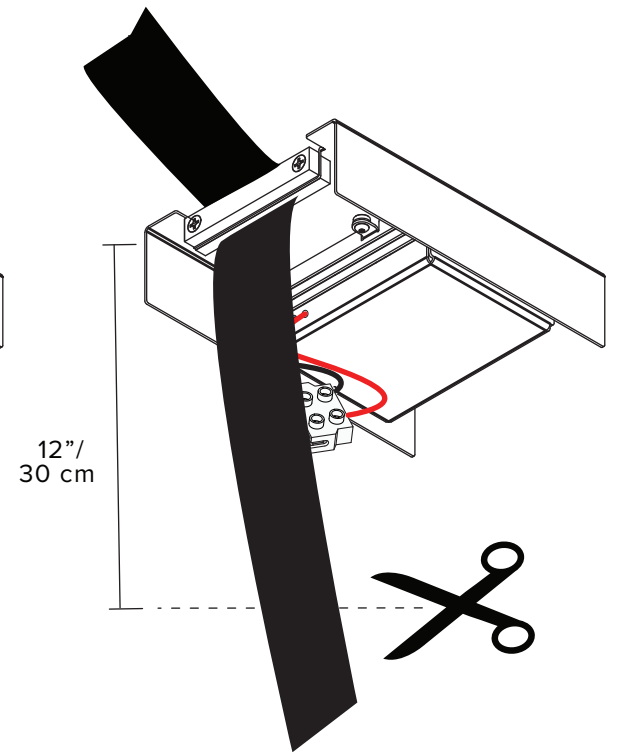

UNSLEEVE CONDUCTORS

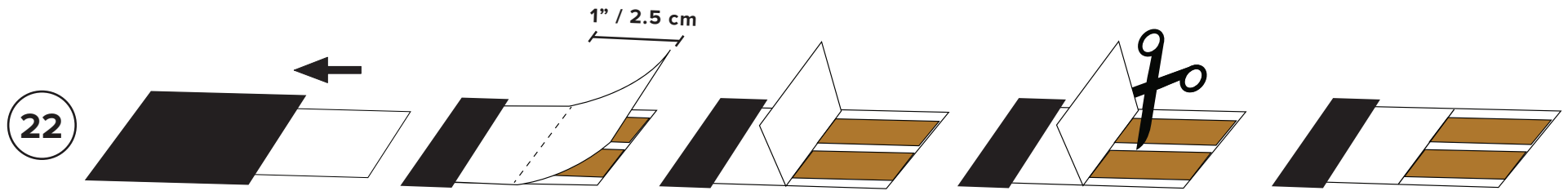

22 Push back the ribbon to reveal the copper conductor.

Peel off and fold 1" / 2.5 cm of the white, shiny covering and cut it off.

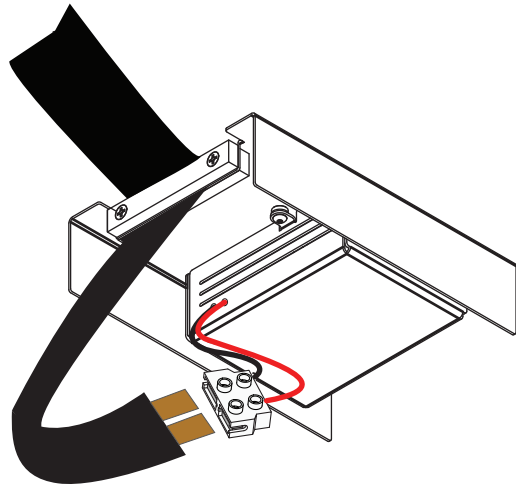

23 Both slots are the same and will receive either ribbon. (Polarity is not important)

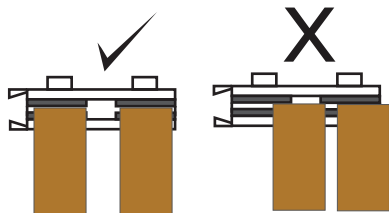

24 Do not overlap ribbons in both connectors

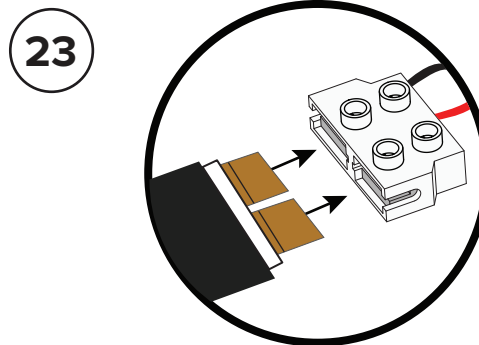

25

Carefully fold up extra ribbon within the housing.

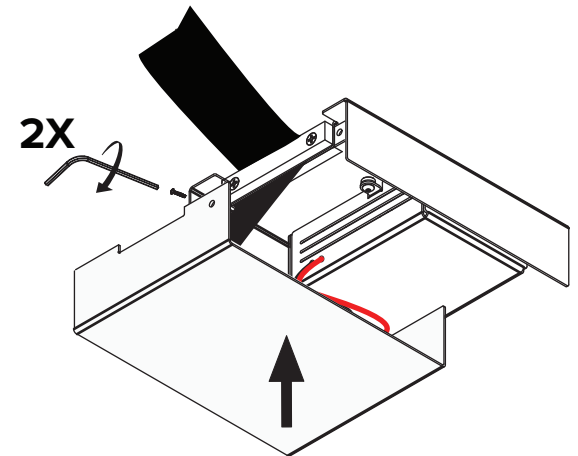

2X

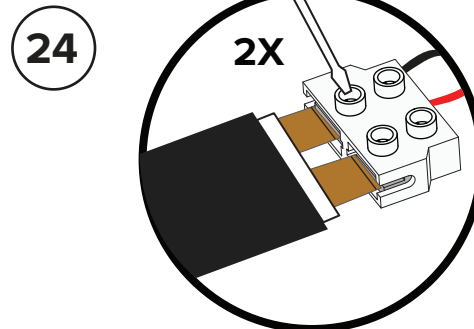

27

Note, one side of canopy cover is slotted for the ribbon

FINAL VERIFICATION

26

When the luminaire is at the desired height and level, trim ribbon 1" / 2.5 cm after the anchor.

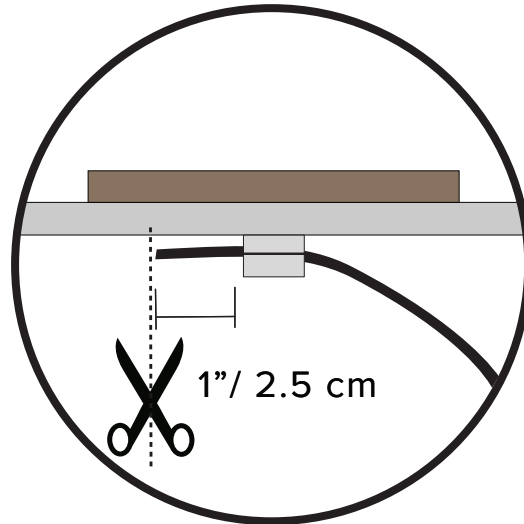

The extremity of the trimmed ribbon can be melted with the flame of a lighter for a few seconds to prevent fraying.

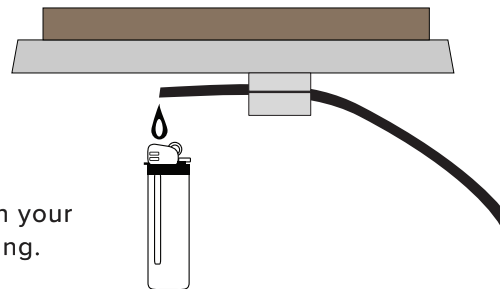

Be careful not to burn your fingers or the ceiling.

27

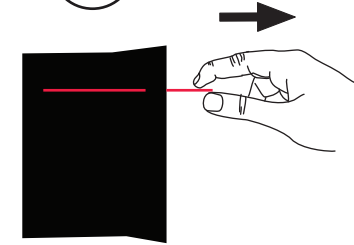

Pull out positioning thread

28

Use a feather duster or microfiber cloth to remove dust.

To clean finger prints, smudges or dirt on the acrylic, gently and very carefully clean the inside and outside of the shade using water and a microfiber cloth, then a dry microfiber cloth.

Do not use abrasive products or contaminated cloth as it could result in scratches on the surface!



**AVOID LIQUIDS
ON THE RIBBON, WIRES
AND LIGHT BLOCK**

