

Colour Temperature Adjustment Guide

Colour temperature adjustment

Applicable on all Mile models

The Mile collection is equipped with the Flex CCT technology that allows you to modify the colour temperature (CCT) of the light source with the simple use of a magnet. The following procedure allows reprogramming, in either fixed colour (**Mode 1**) or Dim-To-Warm feature (**Mode 2**). Dim-To-Warm feature means that the colour will shift to warmer light when dimming. Programming requires a strong magnet about the size of a bottle cap. Be careful not to scratch the lamp surface as the finish is fragile (we recommend using a cloth to cover the magnet).

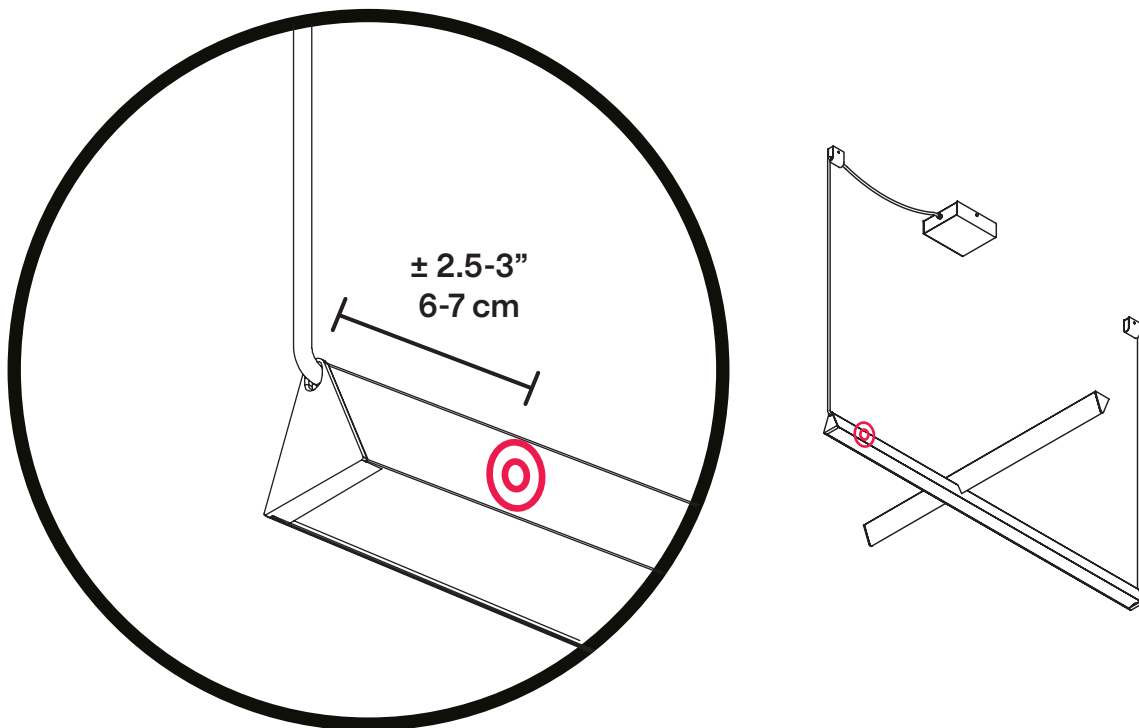

MAGNETIC SENSOR PLACEMENT

Colour Temperature Adjustment Guide

Mode 1 Fixed CCT

Fixed CCT

Light colour will remain the same when dimming.

Step 1: Choose your desired CCT. To find the light pulse sequence refer to Chart 1 (e.g.: 2200K = 1 pulse, 2700K = 6 pulses).

Step 2: Turn ON the luminaire to full brightness. Wait 10 seconds.

Step 3: Bring the magnet up to the sensor area. The position is

approximate. You might have to move the magnet around the suggested area. Once it begins flashing, count the number of flashes corresponding to your selection in Step 1 and remove the magnet before the next flash. After 3 seconds, the lamp will pulse rapidly to indicate programming is complete.

Note: Programming steps can be redone infinitely; simply redo procedure.

CHART 1 - FIXED CCT		
Colour Temperature		Pulse #
WARMEST	2200K	1
	2300K	2
	2400K	3
	2500K	4
	2600K	5
WARM	2700K	6
	2800K	7
	2900K	8
NEUTRAL	3000K	9
	3100K	10
	3200K	11
	3300K	12
	3400K	13
COLD	3500K	14
	3600K	15
	3700K	16
	3800K	17
	3900K	18
COLDEST	4000K	19

Mode 2 Dim-to-Warm

Step 1: Choose your desired CCT. To find the light pulse sequence refer to Chart 2 (e.g.: 2700K dims to 2200K, 50% curve = 2 pulses).

Step 2: Turn ON the luminaire and bring the magnet up to the sensor placement area. When the luminaire starts to flash, you have found the right position. Keep the magnet in position and turn OFF the luminaire for 10 seconds.

Step 3: Keeping the magnet in place, turn ON the luminaire (if using a dimmer, level must be set to MAX/100% light output).

Step 4: After 3-5 seconds, the light will begin flashing. Count the number of flashes corresponding to your selection in Step 1 and remove the magnet before the next flash. The light will flash and transition from warm to cold light showing that a Dim-To-Warm feature has been programmed.

Step 5: Test your programming by dimming your luminaire to see if the light goes from cold to warm.

Note: Programming steps can be redone infinitely; simply redo procedure.

Chart 2 - Presets CCT with Dim-to-Warm feature					
Max Output		Min Output	Transition		Pulse #
	2700K	to	2200K	Normal	1
	2700K	to	2200K	Fast*	2
	3000K	to	2200K	Normal	3
	3000K	to	2200K	Fast*	4
	3500K	to	2200K	Normal	5

*Fast transition implies the lamp will reach minimum output color at 50% dim instead of the normal 25%