

LAURENT 05

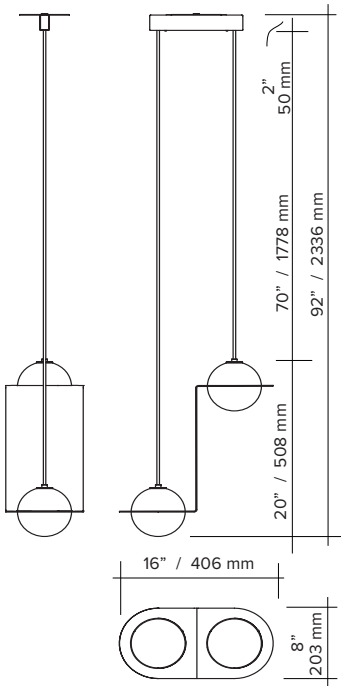

| | |
|-----------------------|--|
| type | suspension |
| materials | sphere: handblown opaline glass |
| | frame: polished brass (BR) or powder coated aluminum (Colors) or nickel plated steel (CH) |
| | hardware: polished brass or powder coated aluminium |
| | wire: nylon/polyester |
| weight | 9 lb / 4 kg |
| light bulb | LED (included), 4,5W (see lightbulb section for specifications) |
| sockets | G9 |
| voltage | 120V / 240V |
| dimmer | refer to our recommended list of dimmer models |
| certifications | |
| notes | <ul style="list-style-type: none"> - must be installed by an electrician - additional charges for modifications or for special orders - lead time between 7-9 weeks. - dimensions are approximate and may vary slightly. |

parallel wires



parallel wires with offset connection

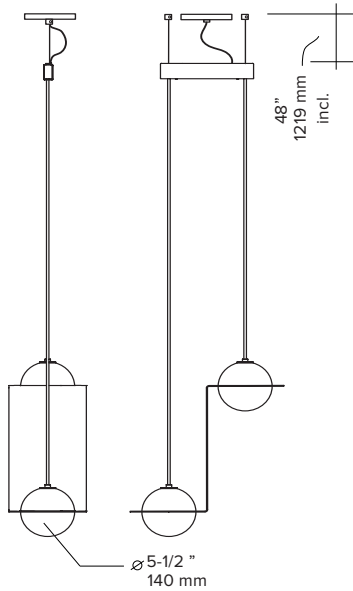

angled wires

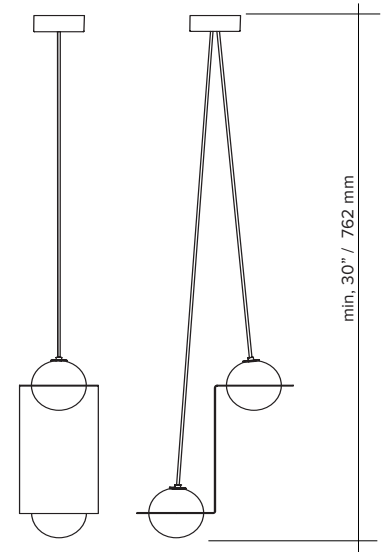

ORDER GUIDE: SKU

| COLLECTION | MODEL | FINISH (frame + wire system) | CANOPY | MOUNTING TYPE |
|-------------|-------|---|-----------------|--|
| LRT Laurent | 05 | BLBL black + black BRBL brass + black BRGD brass + gold CHBL chrome + black CHBE chrome + blue BEBL blue + black BEBE blue + blue BUBL burgundy + black BUSA burgundy + sand BUBU burgundy + burgundy TUBL turquoise + black TUSA turquoise + sand | BL black | AW angled wires PW parallel wires |
| LRT | 05 | BLBL | BL | AW |

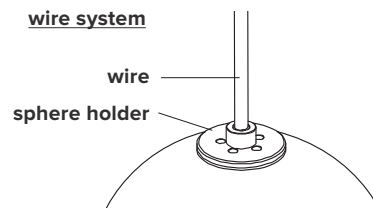
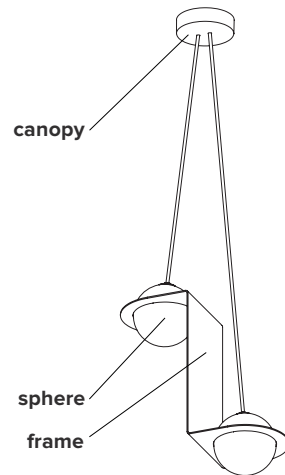

= **LRT05BLBLBLAW**
example

FRAME FINISH



textured black



textured blue



textured burgundy



textured turquoise

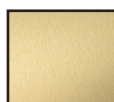

brass



chrome

MOUNTING COLOUR sphere holder & wires



textured black



textured blue



textured burgundy



textured sand

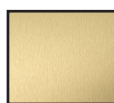

gold



textured black



flat white

CANOPY COLOR custom color available on demand

MOUNTING TYPE



textured black

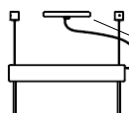
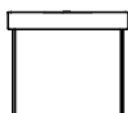

flat white

textured black

angled wires

parallel wires

LIGHT BULB & DIMMER SPECIFICATIONS

G9 SOCKETS

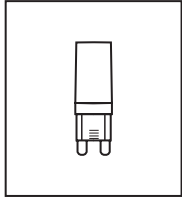

Frosted
4.5W
100V-120V / 240V
450 Lumens
2700 K
25 000 H
CRI ≥80
2 years warranty



DIMMER LIST COMPATIBILITY FOR G9 LED BULBS – 120V

The dimming technology offering the best results is ELV (electronic low voltage) dimmers with reverse phase or trailing edge control.

| <u>DIMMER BRAND</u> | <u>MODEL NUMBER</u> | <u>MAX LEVEL</u> | <u>MIN LEVEL</u> | <u>FLICKERING</u> | <u>OVERALL QUOTE</u> |
|---------------------|---------------------|------------------|------------------|-------------------|----------------------|
| LUTRON - MAESTRO | MAELV-600 | 100% | 0% | 0%-10% | good |
| LUTRON - SKYLARK | SELV-300P | 100% | 0% | no | very good |
| LUTRON - SKYLARK | SELV-303P | 100% | 0% | no | very good |
| LUTRON - SKYLARK | CTELV-303P | 100% | 0% | no | very good |
| LUTRON - DIVA | DVELV-300P | 100% | 0% | no | very good |
| LEGRAND - ADORNE | TRUE UNIVERSAL | 100% | 30% | no | good |

DIMMER LIST COMPATIBILITY FOR G9 LED BULBS – 230V

| <u>DIMMER BRAND</u> | <u>MODEL NUMBER</u> | <u>MAX LEVEL</u> | <u>MIN LEVEL</u> | <u>FLICKERING</u> | <u>OVERALL QUOTE</u> |
|---------------------|---------------------|------------------|------------------|-------------------|----------------------|
| VARILIGHT | V-PRO | 100% | 2% | no | very good |
| LEGRAND - NILOÉ | 3 996 35 | 87% | 15% | no | good |
| NIKO | 310-0280X | 94% | 5% | no | very good |
| NIKO | 310-0190X | 100% | 1% | no | very good |

*Other dimmers can yield good results and we recommend conducting your own test before final installation.