

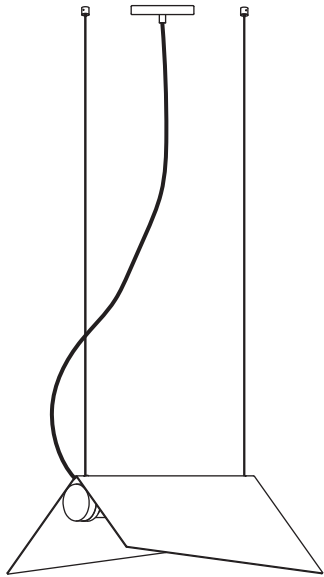

CLARK SUSPENSION

2 x  1 x  1 x  2 x  2 x 





- To be installed by an electrician to an electrical box
- Use appropriate screws and anchors where necessary
- Wear enclosed gloves when handling lamp
- Handle materials with care. Please consult lamp maintenance sheet on our web site

lamp weight 13 lbs / 6 kg



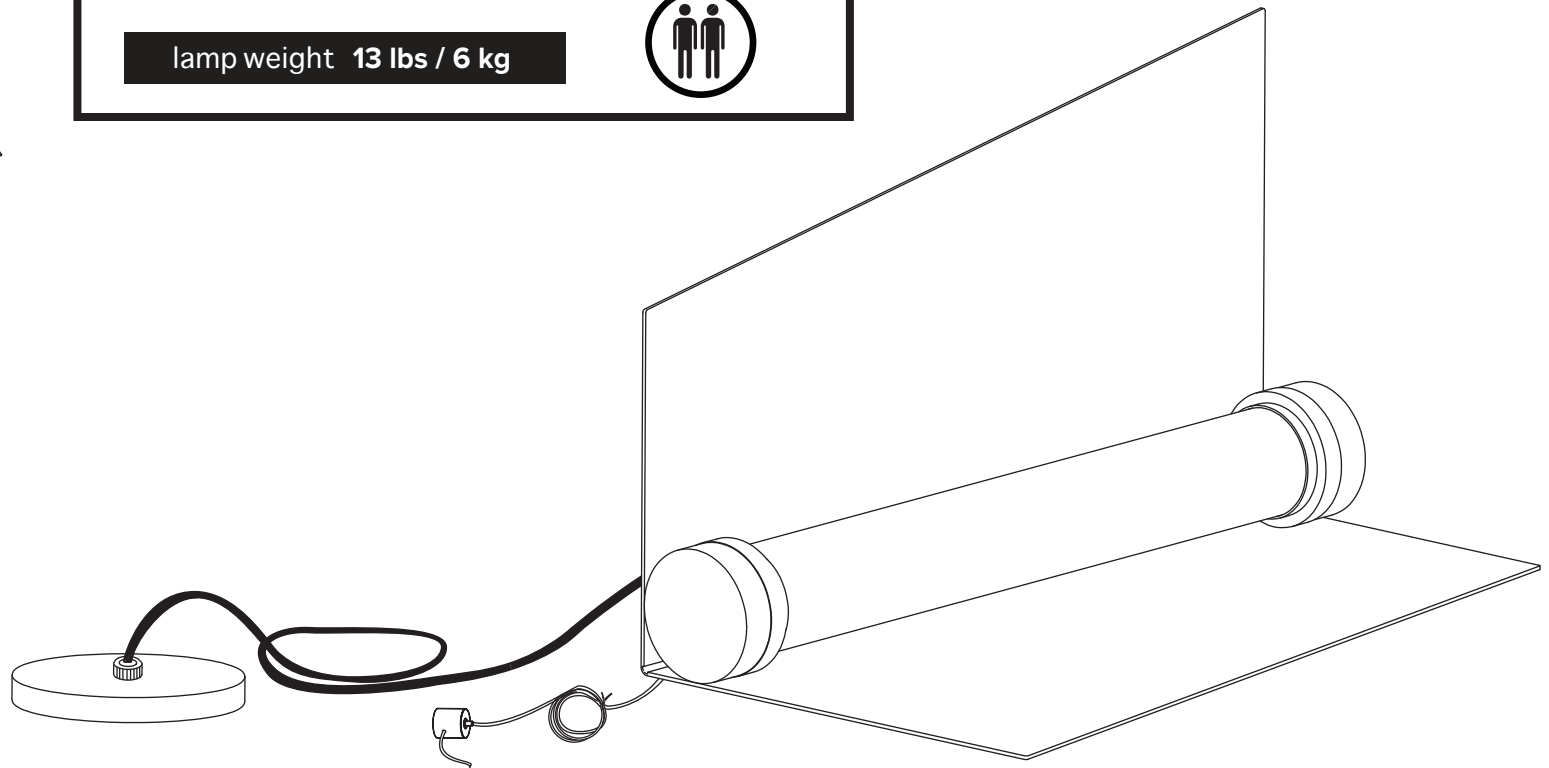

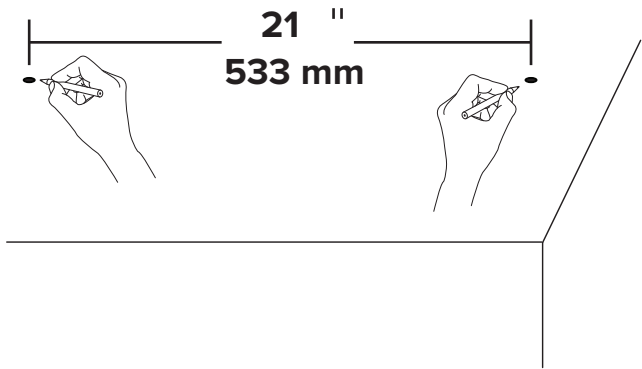

1

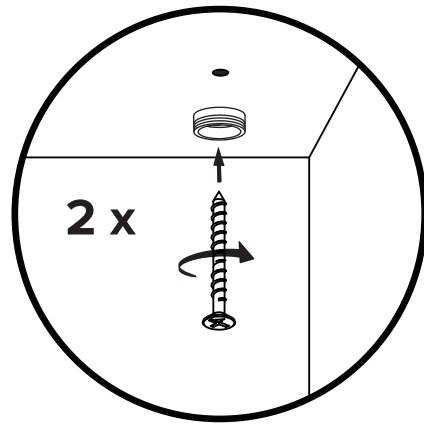

* Use appropriate anchors

2

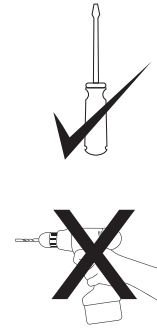

Each anchor must be able to support 32.5 lbs / 15 kg

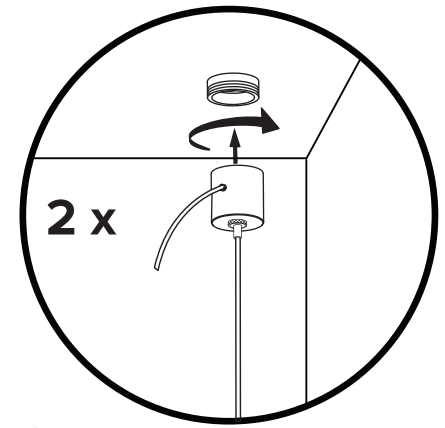

3

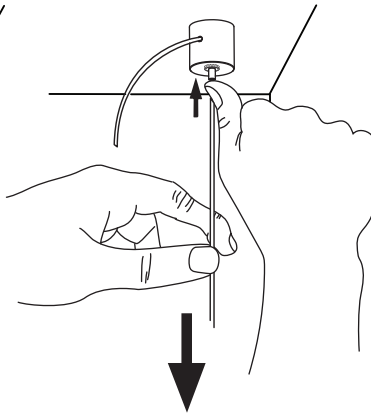
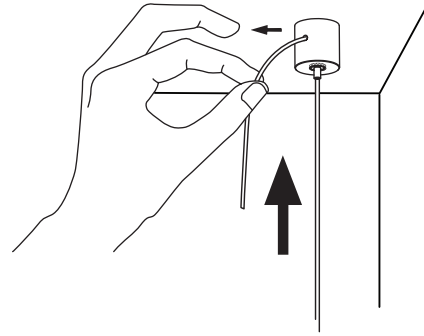
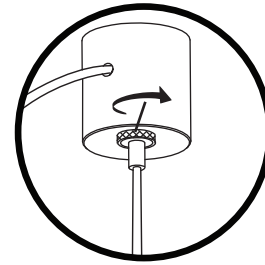
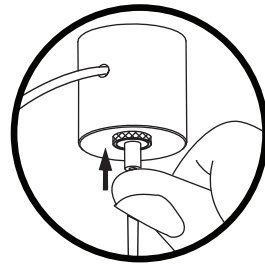
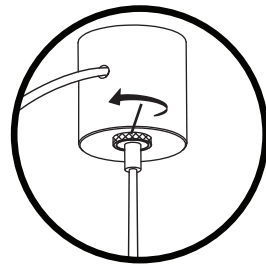
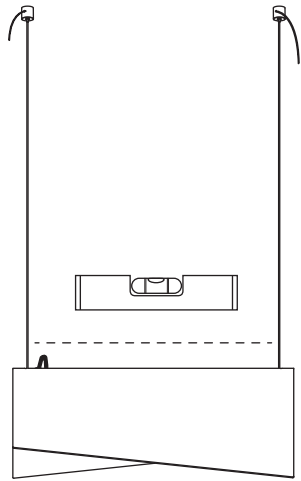

4

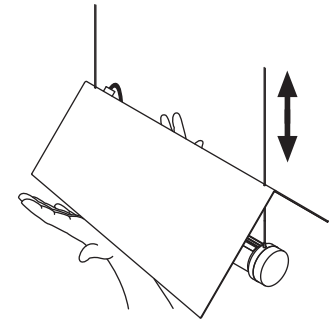

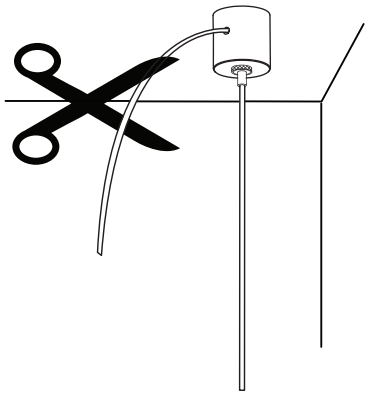

5

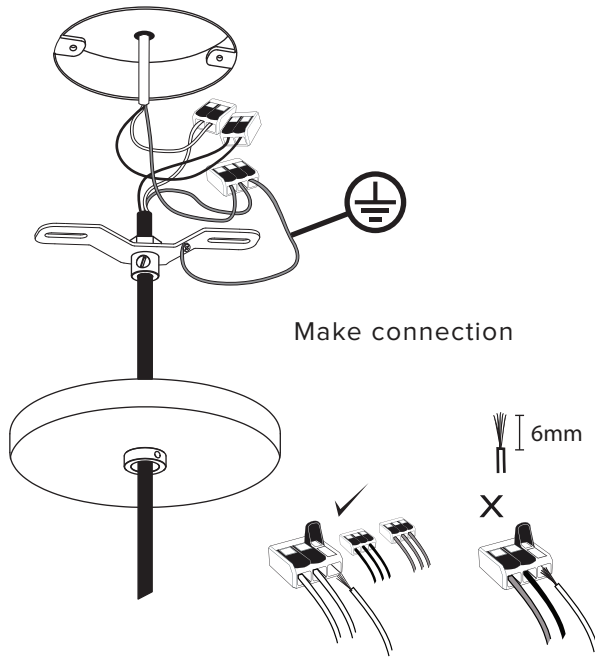

6

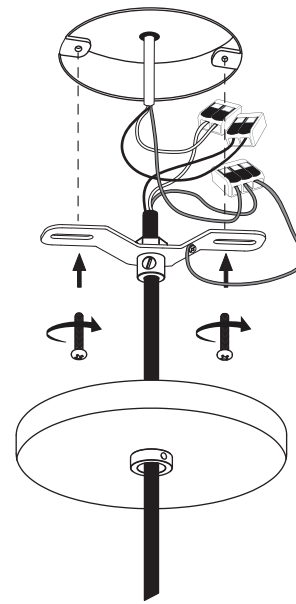

7

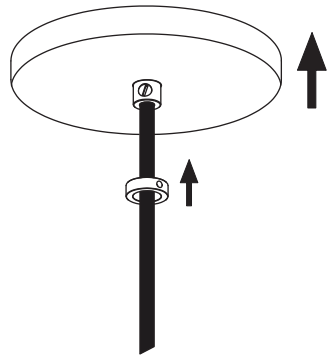
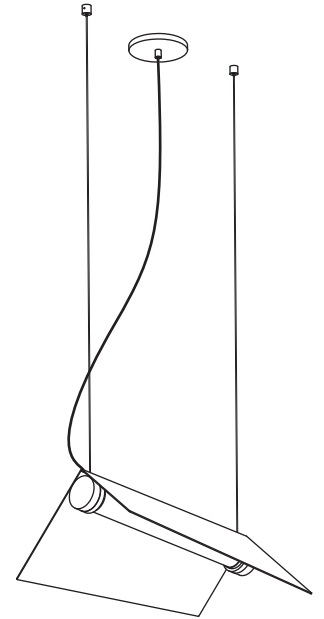

8

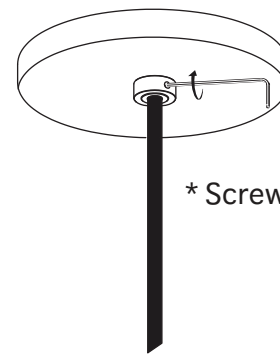

9

* Screw gently, but firmly