

LAURENT 17

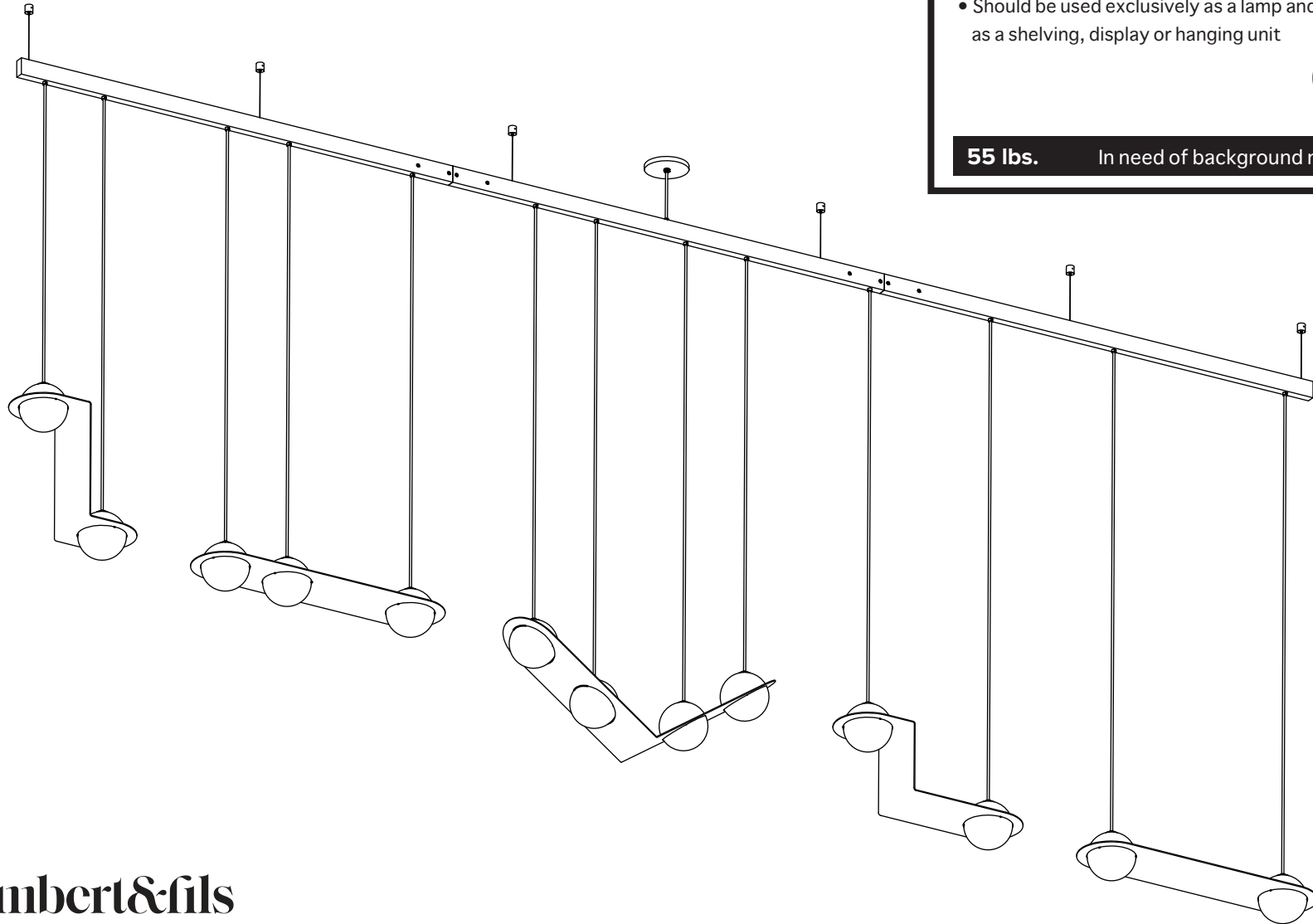

- To be installed by an electrician to an electrical box
- Use appropriate screws and anchors where necessary
- Wear enclosed gloves when handling lamp
- Handle materials with care. Please consult lamp maintenance sheet on our web site
- Should be used exclusively as a lamp and not as a shelving, display or hanging unit



55 lbs.

In need of background nailing

To ensure easy assembly and efficient shipping, the lamp has been shipped as three parts that are assembled together

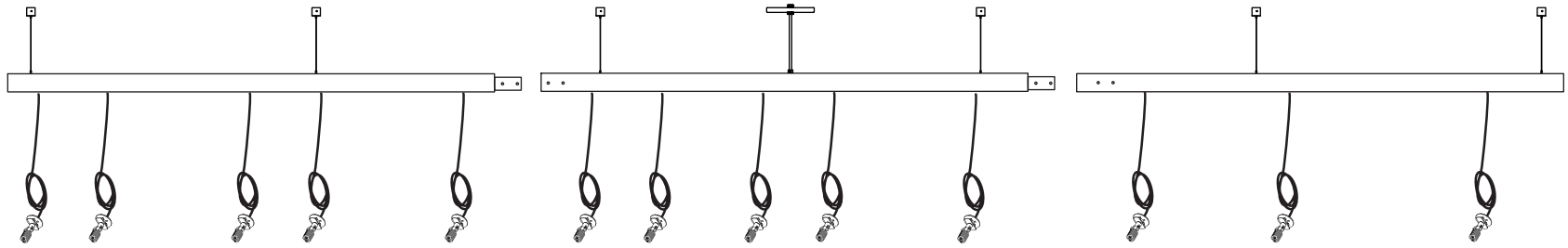

1

Make connection between bars.

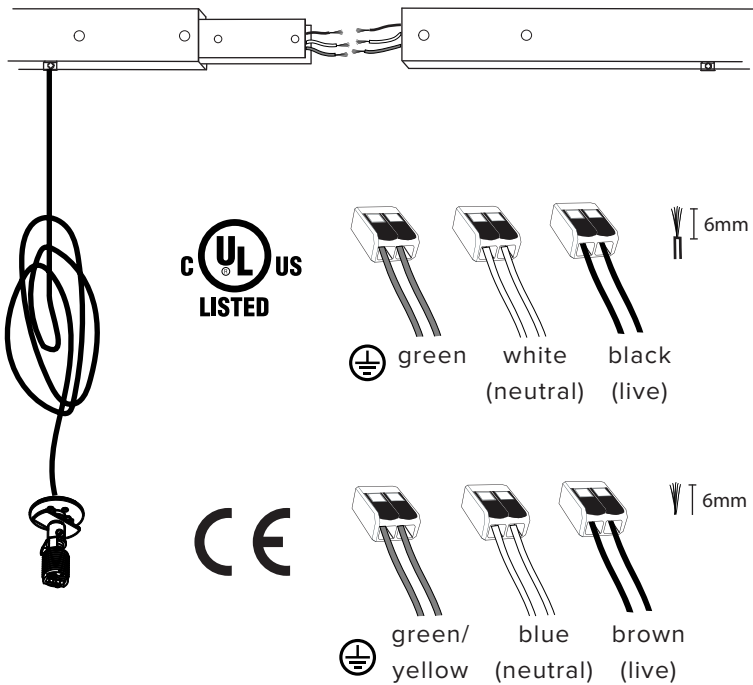

2

Carefully place wires and Waggos in between connecting plates of the bars before sliding the bars together.

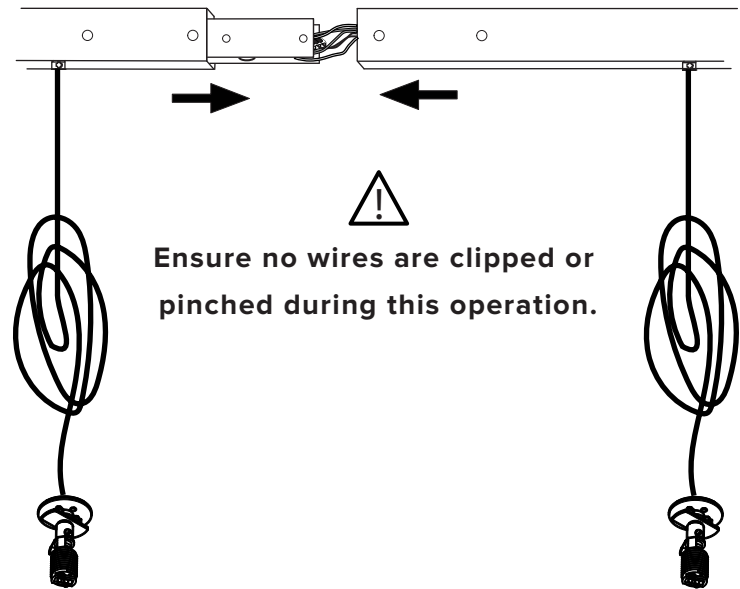

3

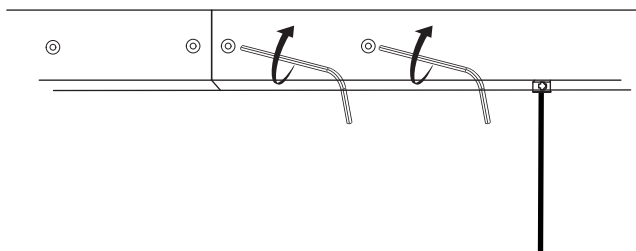

SCREW GENTLY BUT FIRMLY

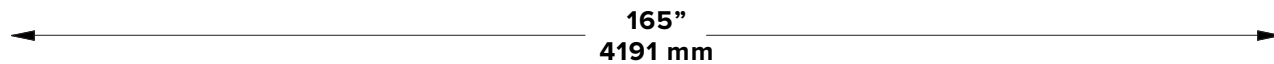

4

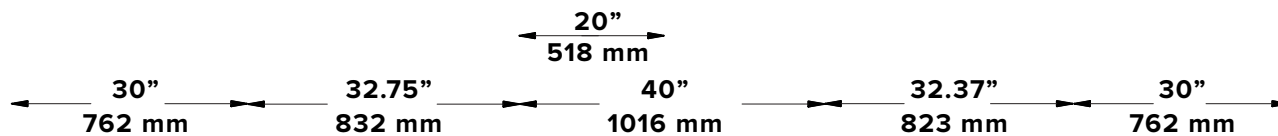

Mark anchor locations using your electrical box and canopy as a guide

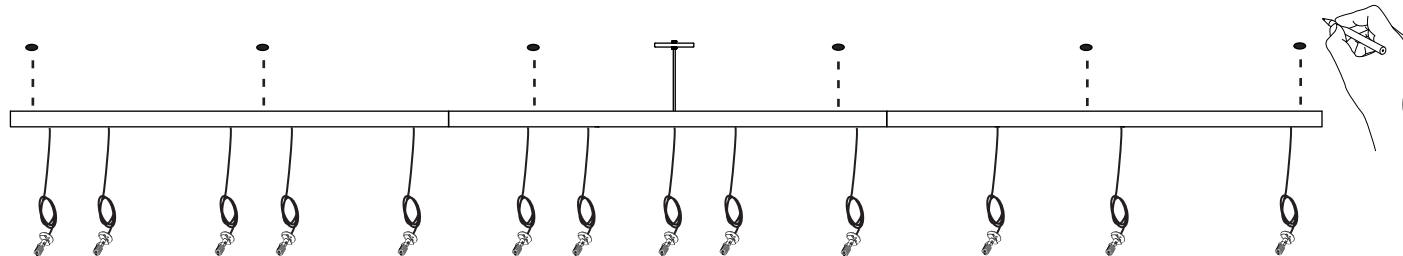

5

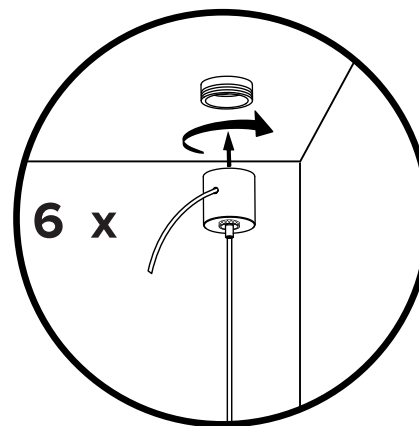
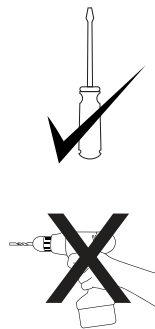
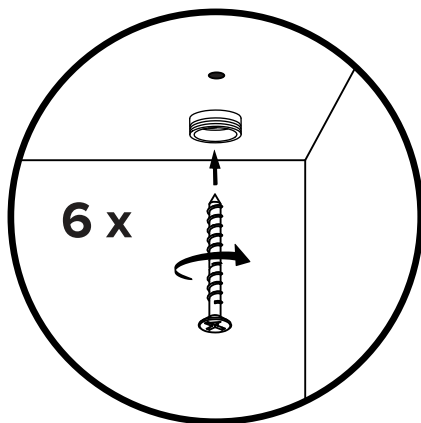

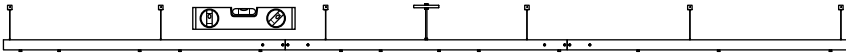

6

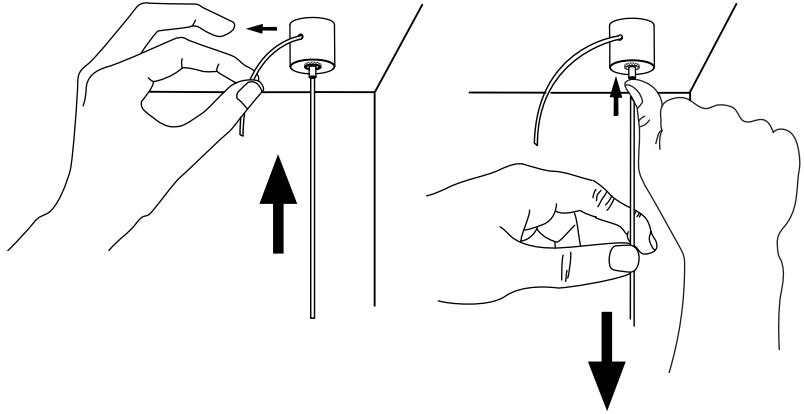
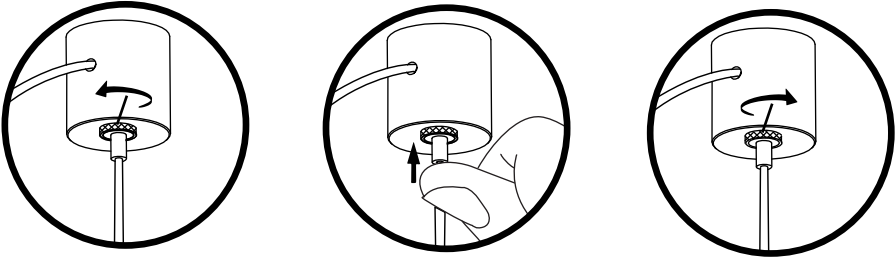

7

Trim wires to desired length (X).
Do not leave a large excess of wires inside the canopy.
Reconnect them as before. Do this step before
making electrical connection.

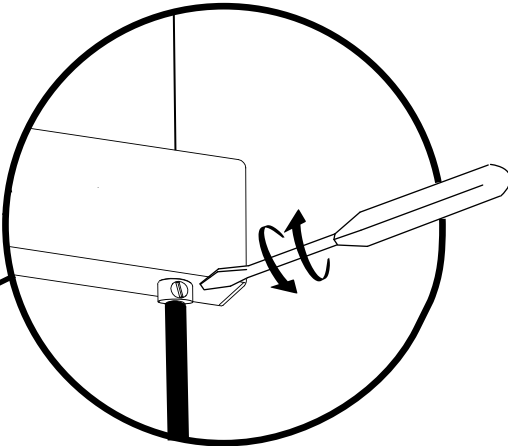
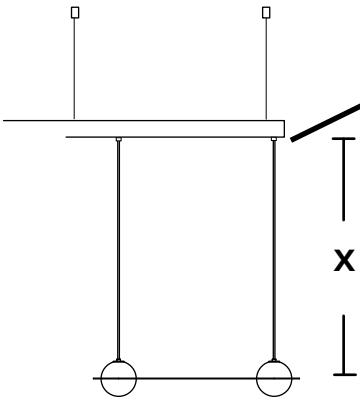

Loosen set screw to adjust
wire length. Screw back gently
but firmly, when desired wire
length is reached.

8

Trim extra cable when
desired level and height
are achieved

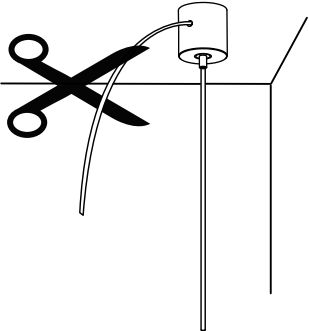

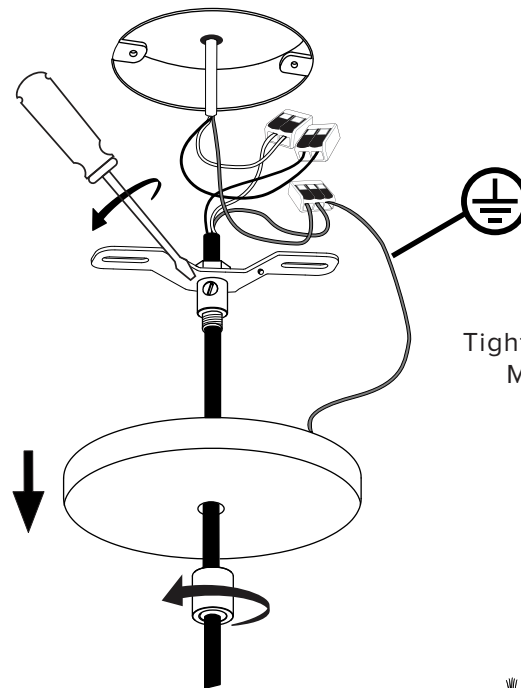
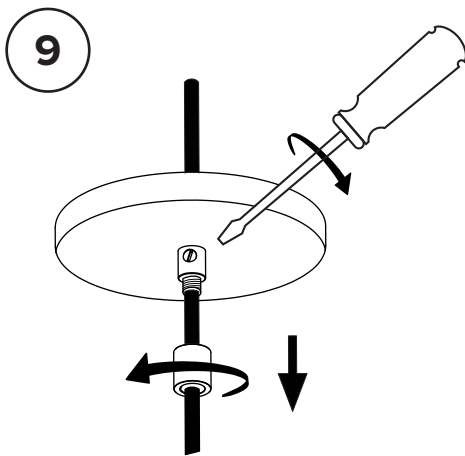

10

Tighten nylon set screw.
Make connection.

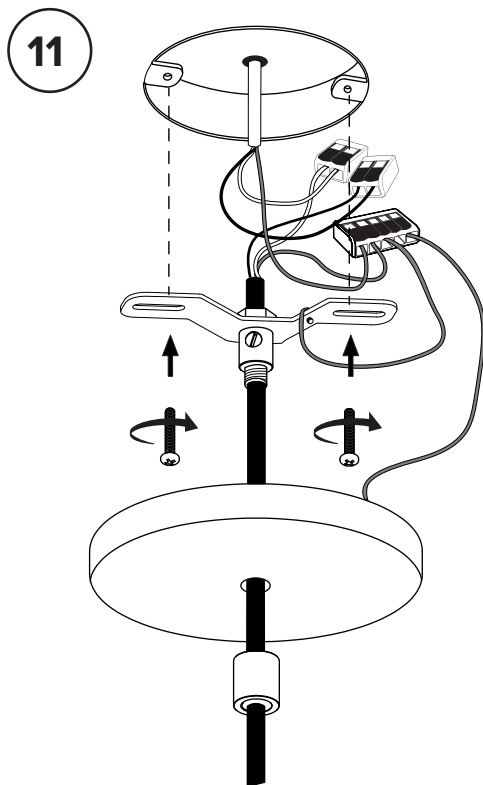
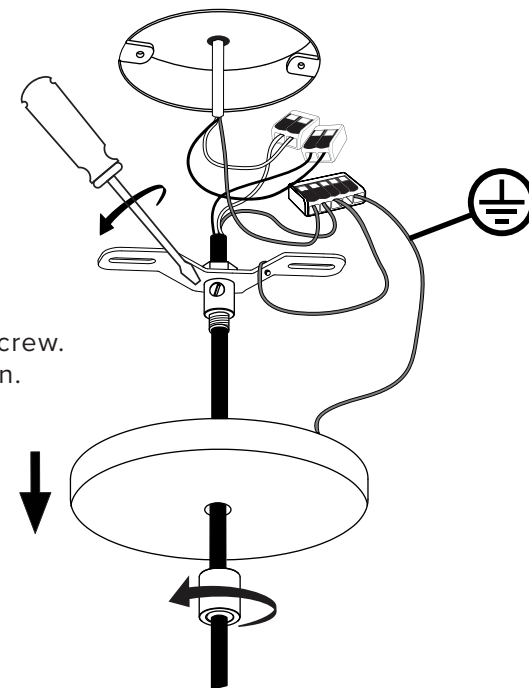

c **UL** US
LISTED

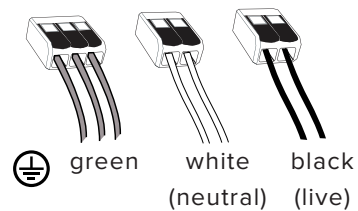

6mm

CE

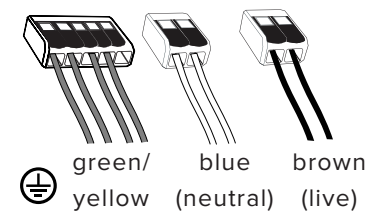

12

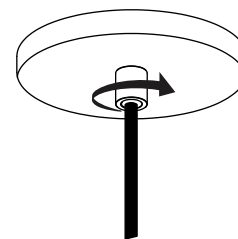
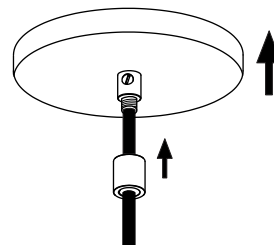

13

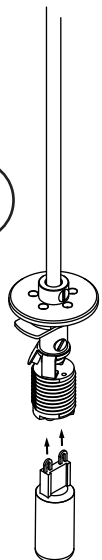

A

14

B

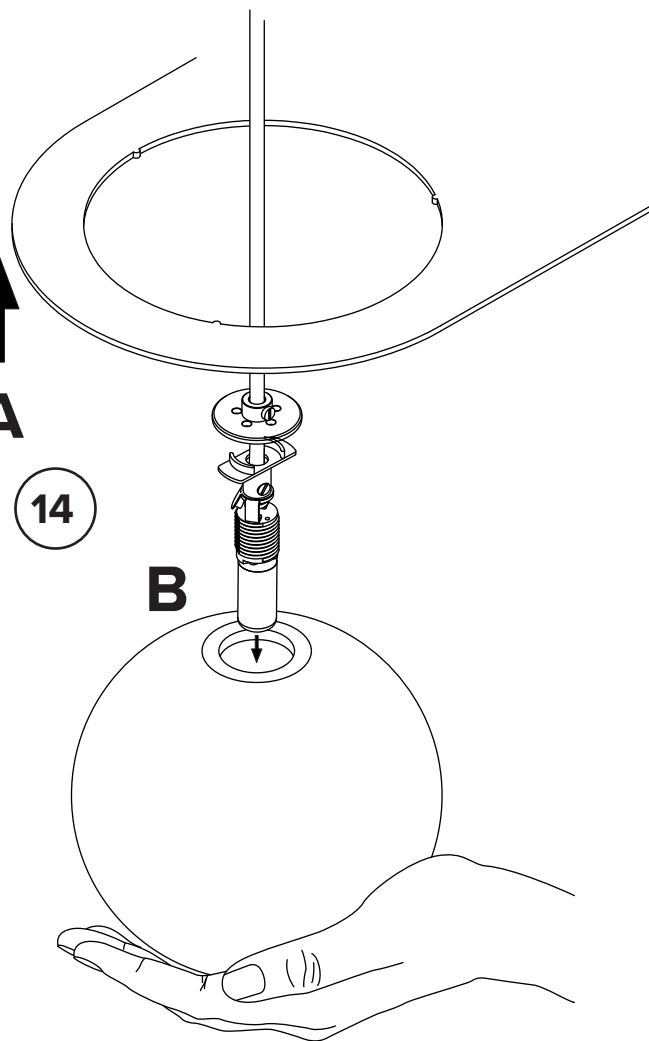

15

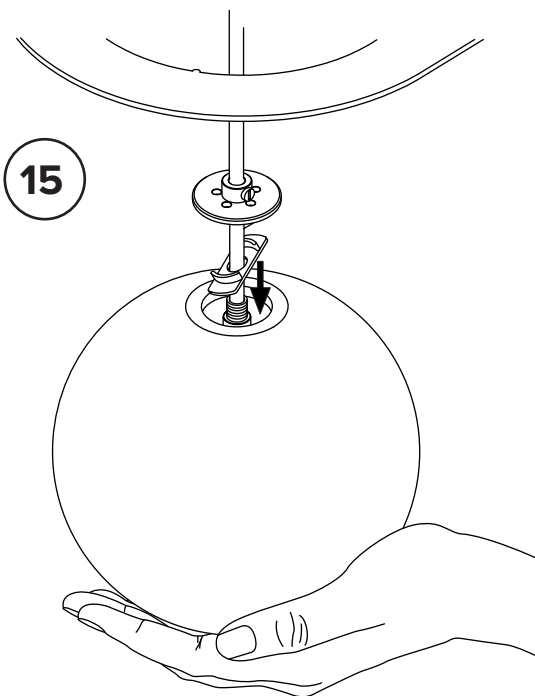

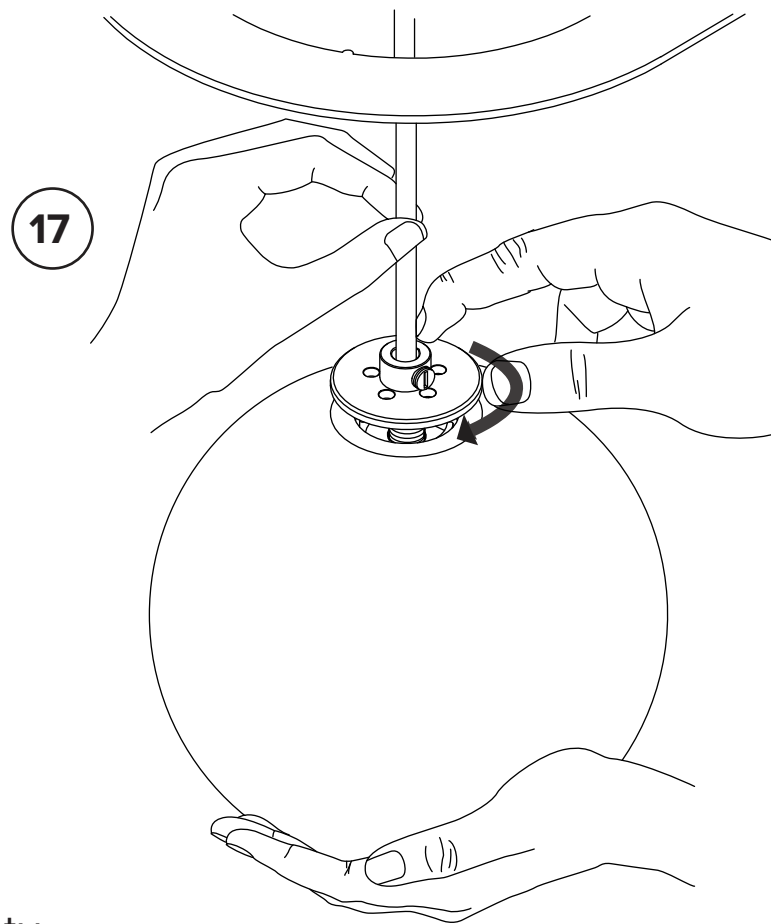
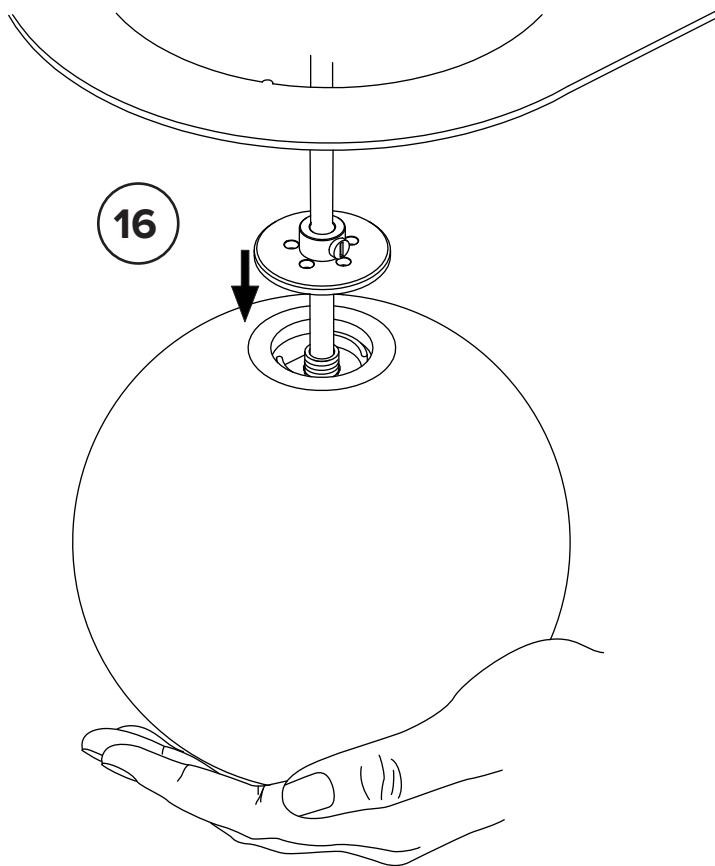

* To ensure safety,
**PLEASE FOLLOW THESE STEPS
CAREFULLY**

* To ensure safety,
**PLEASE FOLLOW THESE STEPS
CAREFULLY**

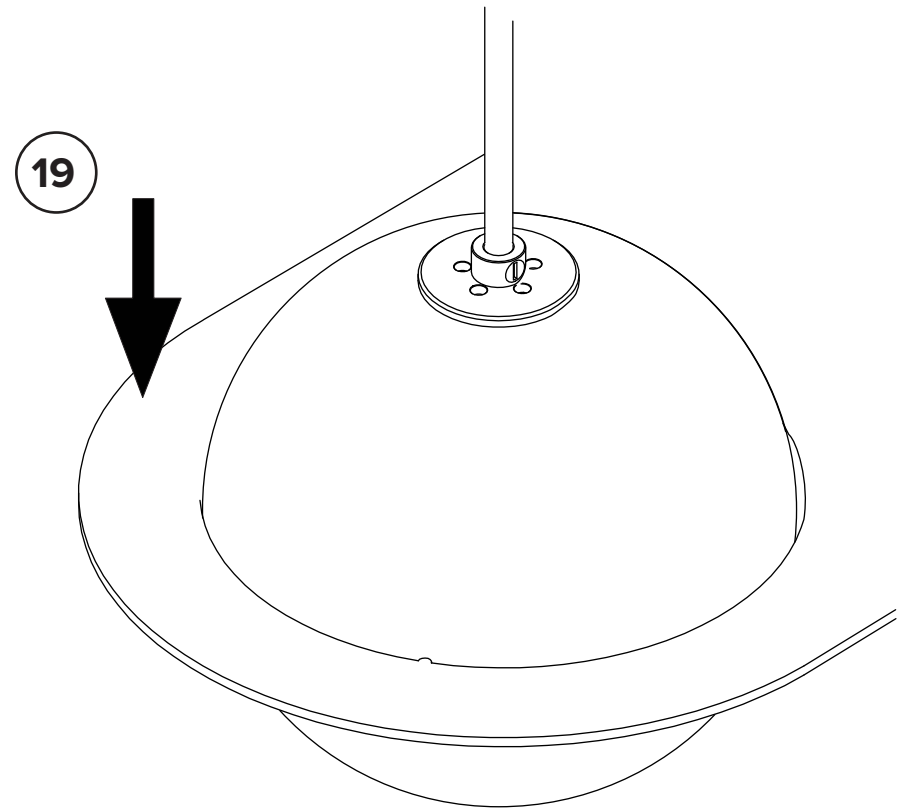
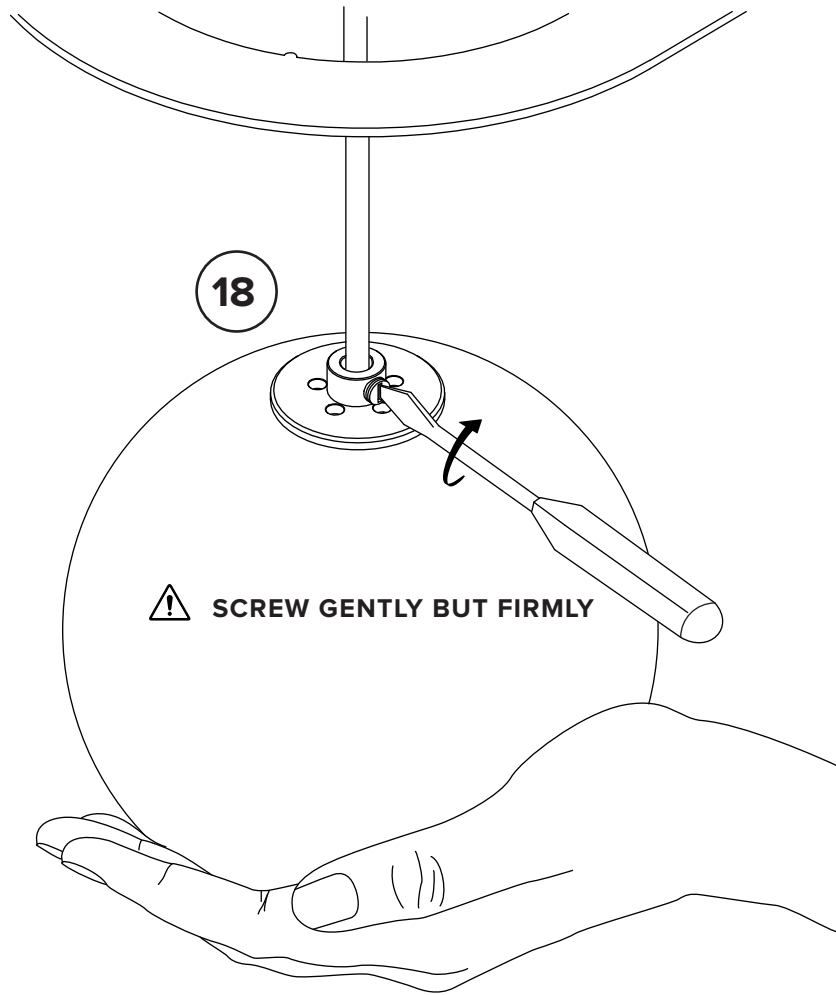

20

Make sure the globes are level by micro-adjusting the wire lengths.

SCREW GENTLY BUT FIRMLY

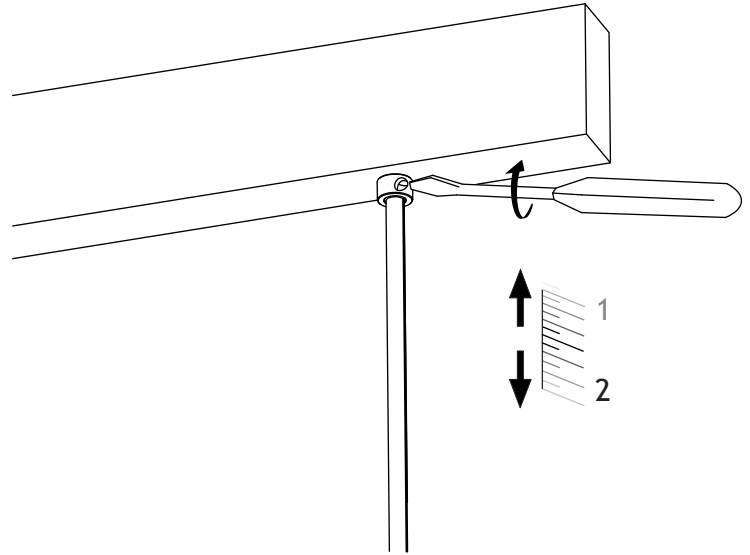
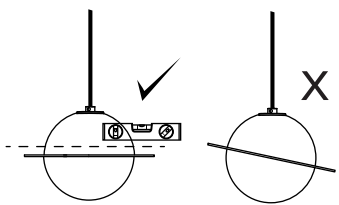

21

Trim cables when final height and level are achieved

