

LAURENT 09

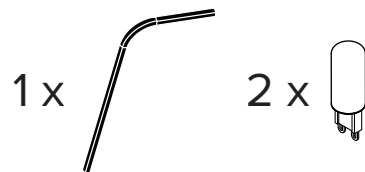

- To be installed by an electrician to an electrical box
- Use appropriate screws and anchors where necessary
- Wear enclosed gloves when handling lamp
- Handle materials with care. Please consult lamp maintenance sheet on our web site
- Should be used exclusively as a lamp and not as a shelving, display or hanging unit

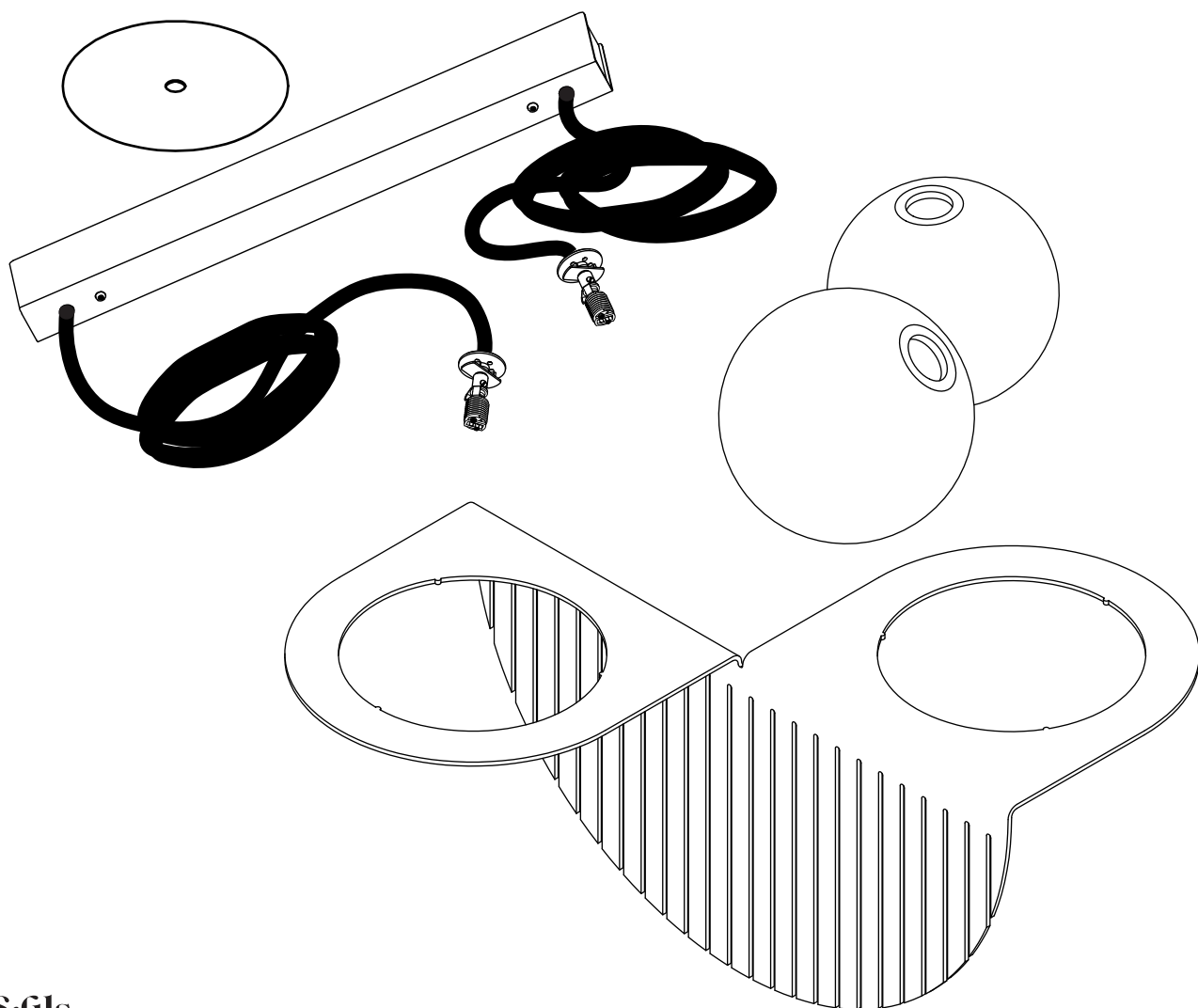
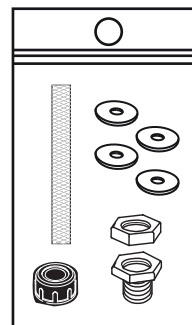

1

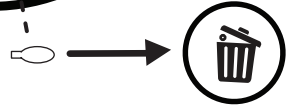
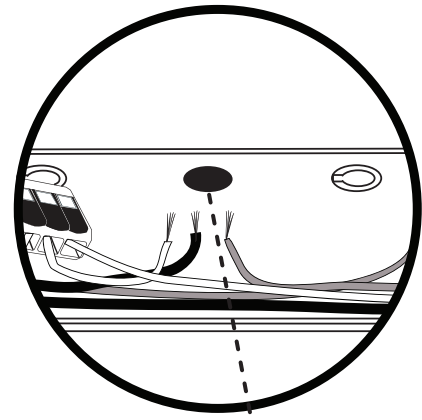
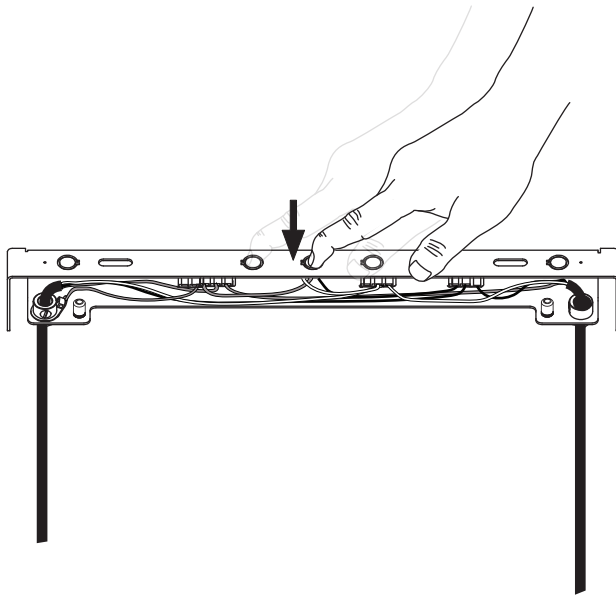

Knockout selected hole depending on desired electrical box alignment.

2

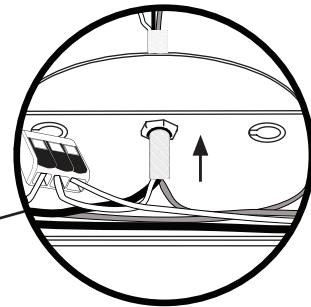
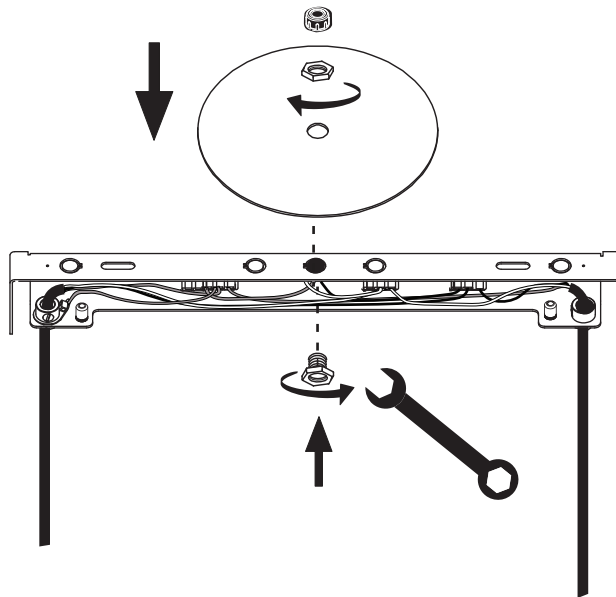

3

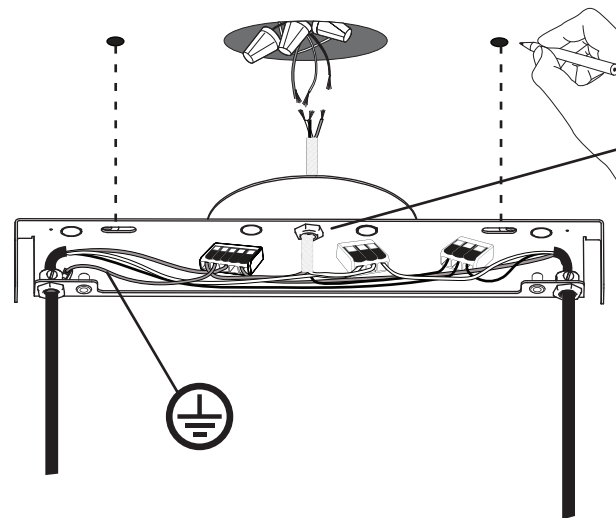

Before marking your anchor locations, align the ceiling bracket with the center of your junction box.

Feed wires through anti-abrasive sleeve before making connection

Make sure to use appropriate anchors for ceiling material.

4



Make connection  6mm

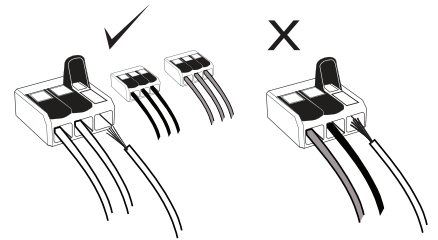

5

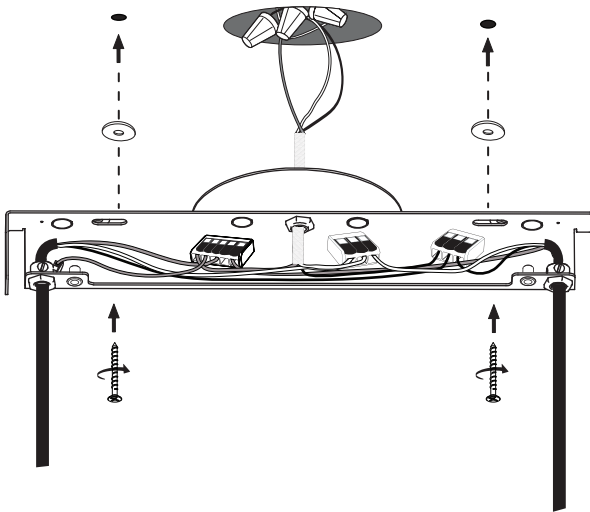

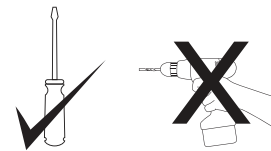
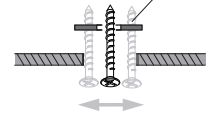

SMALL SPACING WASHER

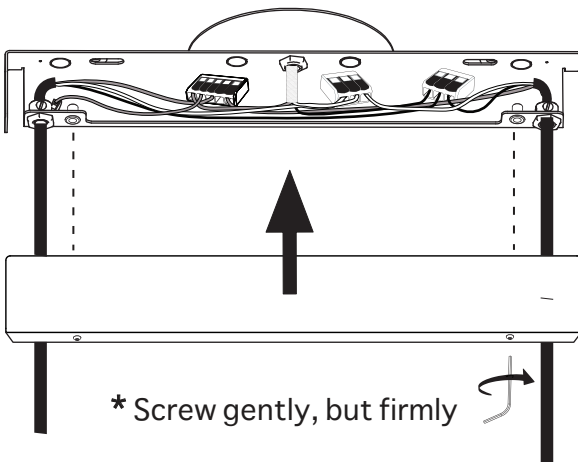

Avoid scuffing wires during this operation.

6



* Screw gently, but firmly 

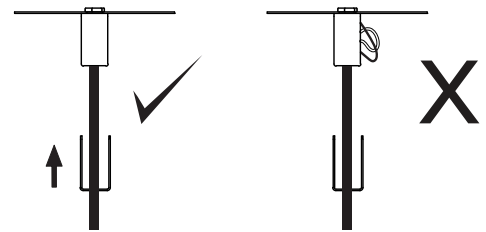

Ensure no wires are clipped or pinched during this operation.

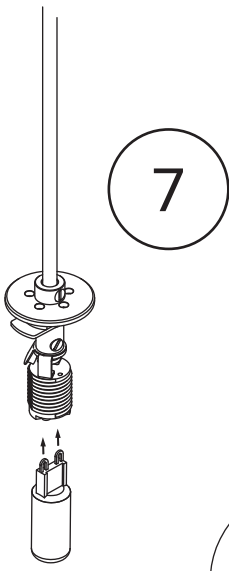

7

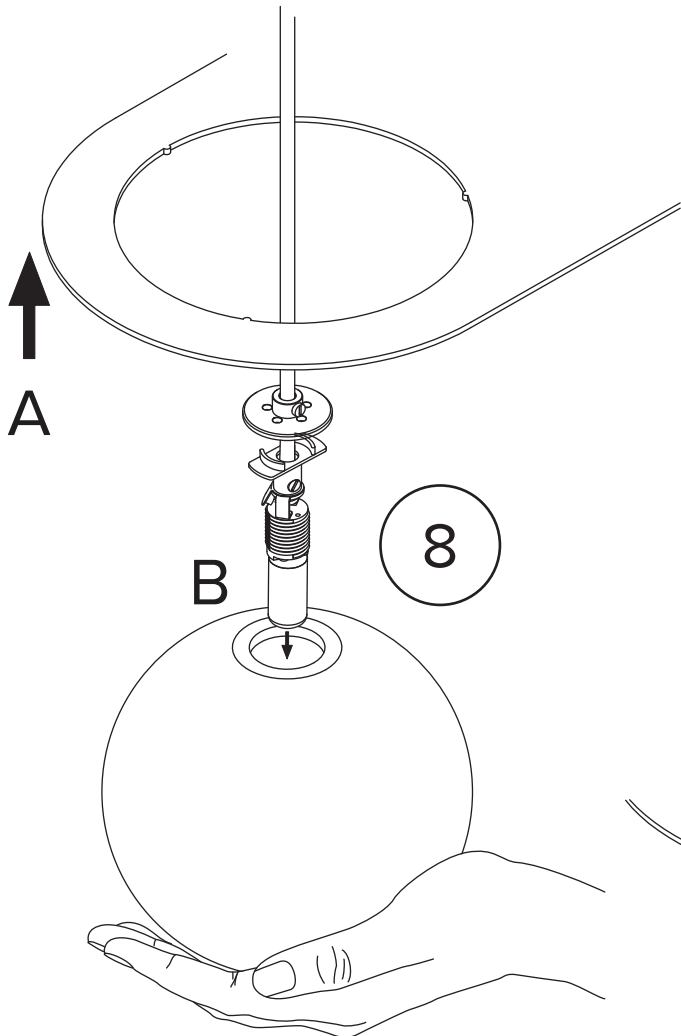

8

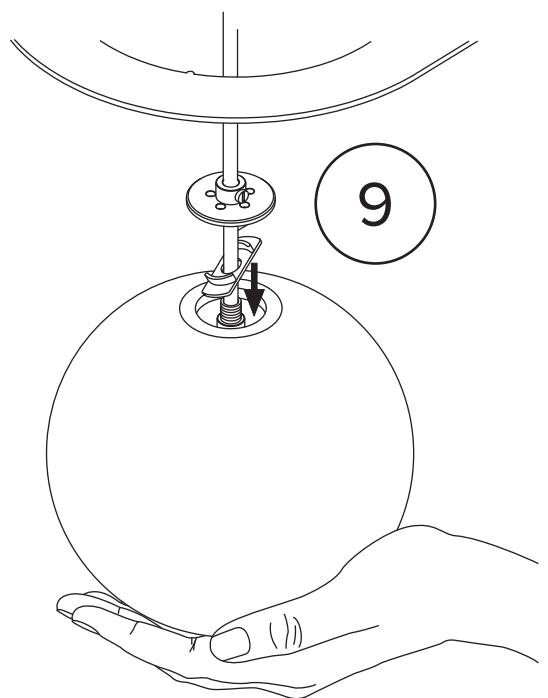

9

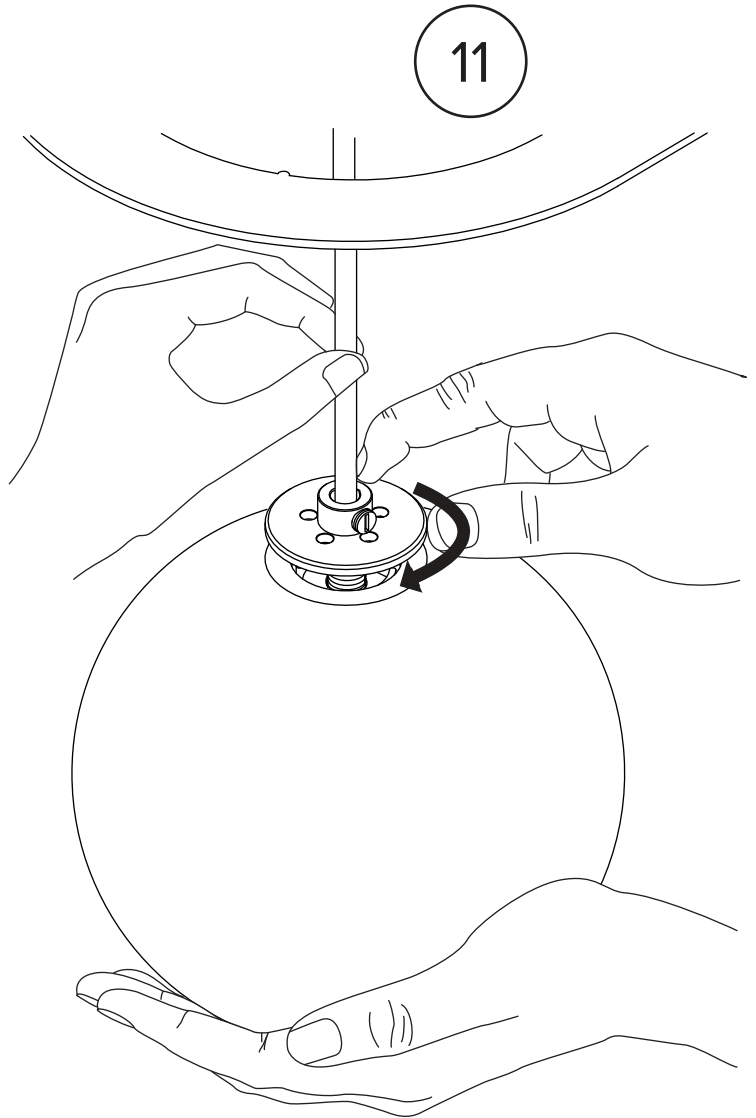
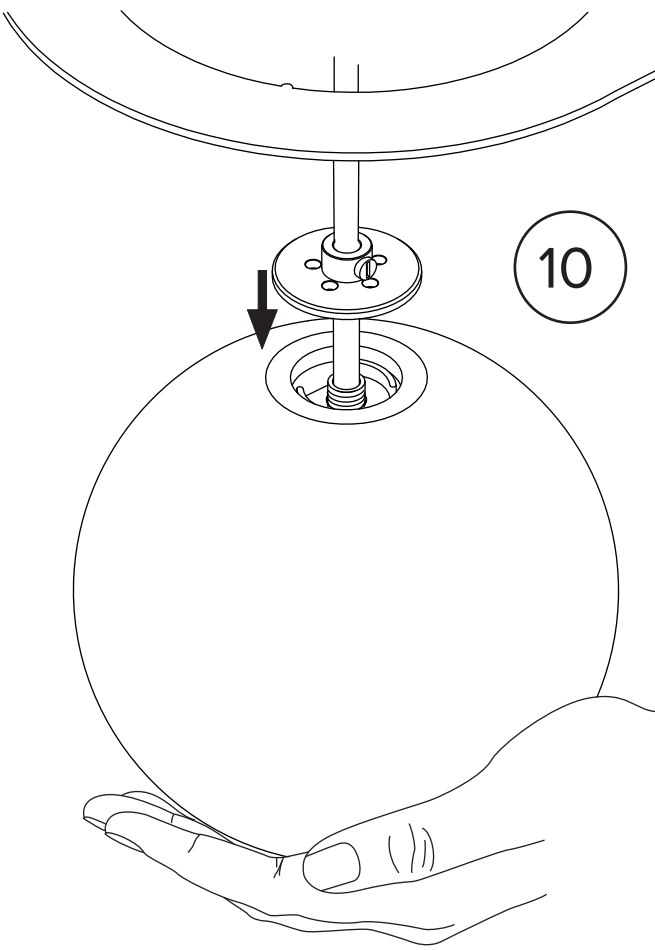

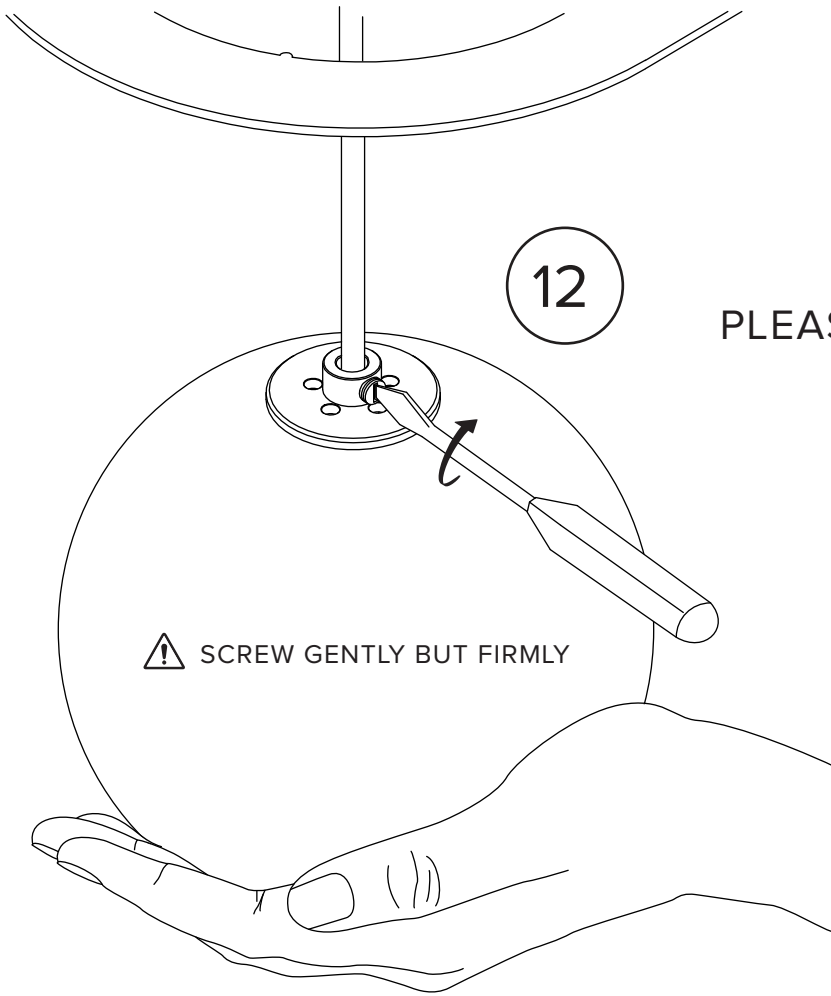

* To ensure safety,
PLEASE FOLLOW THESE STEPS
CAREFULLY

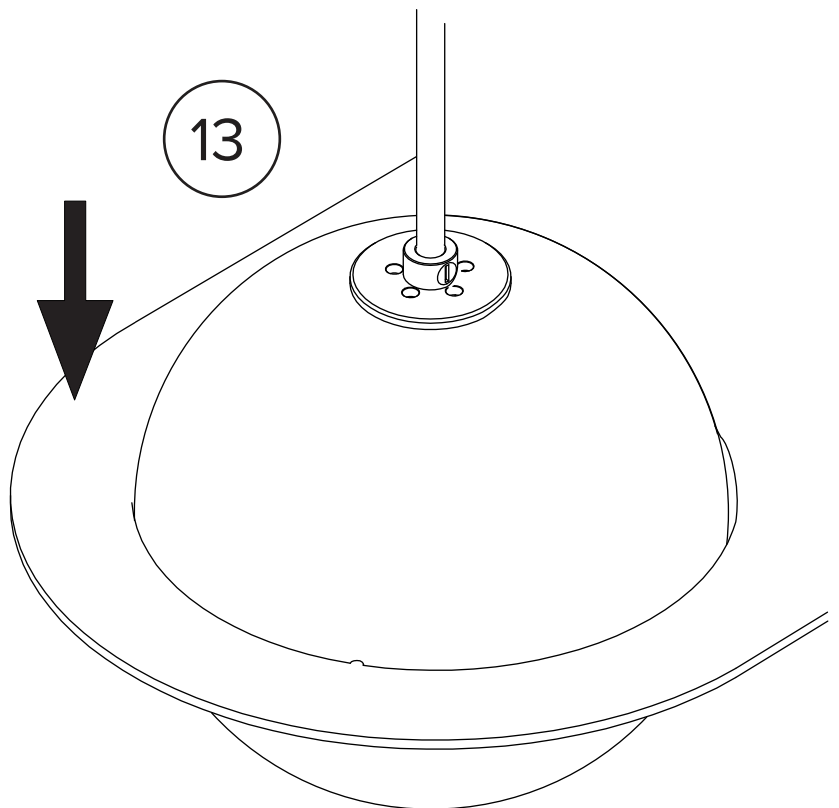

14

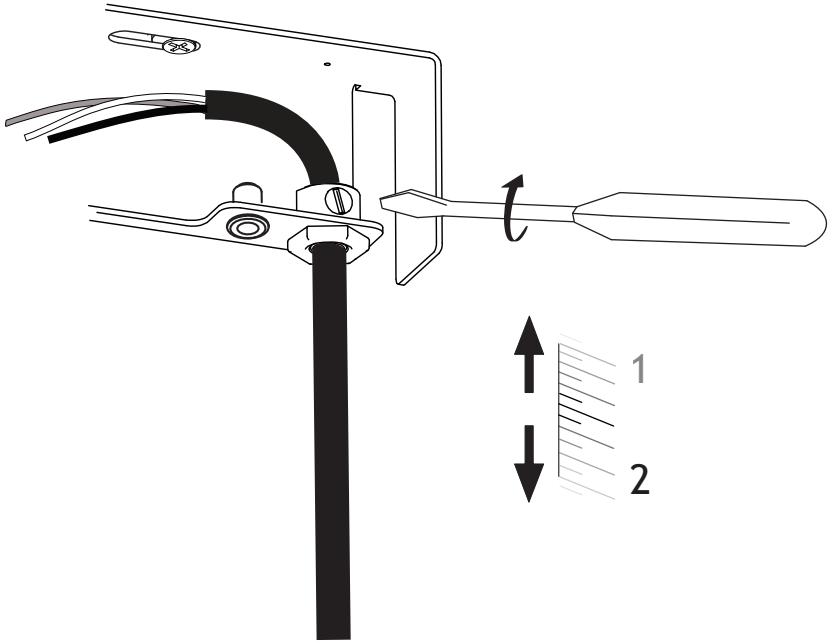

Make sure the globes are level by micro-adjusting the wire lengths.

SCREW GENTLY BUT FIRMLY

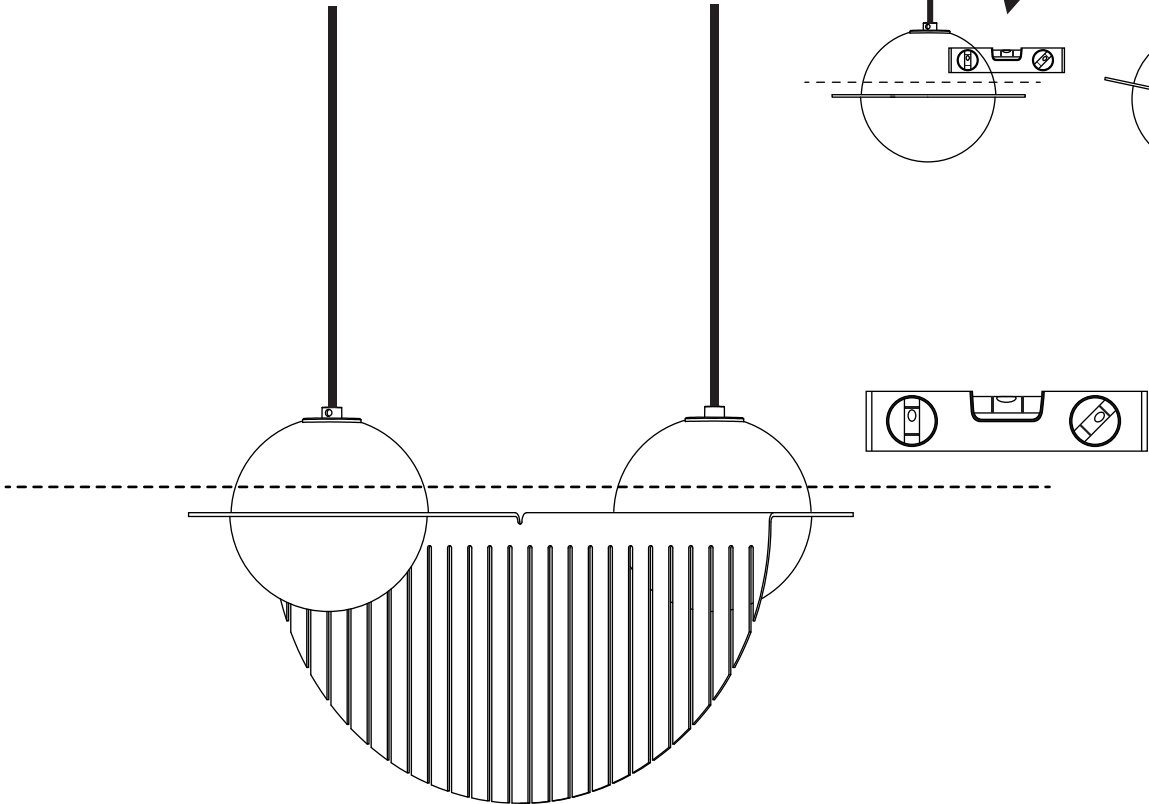
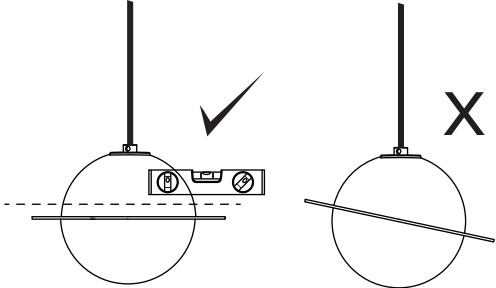

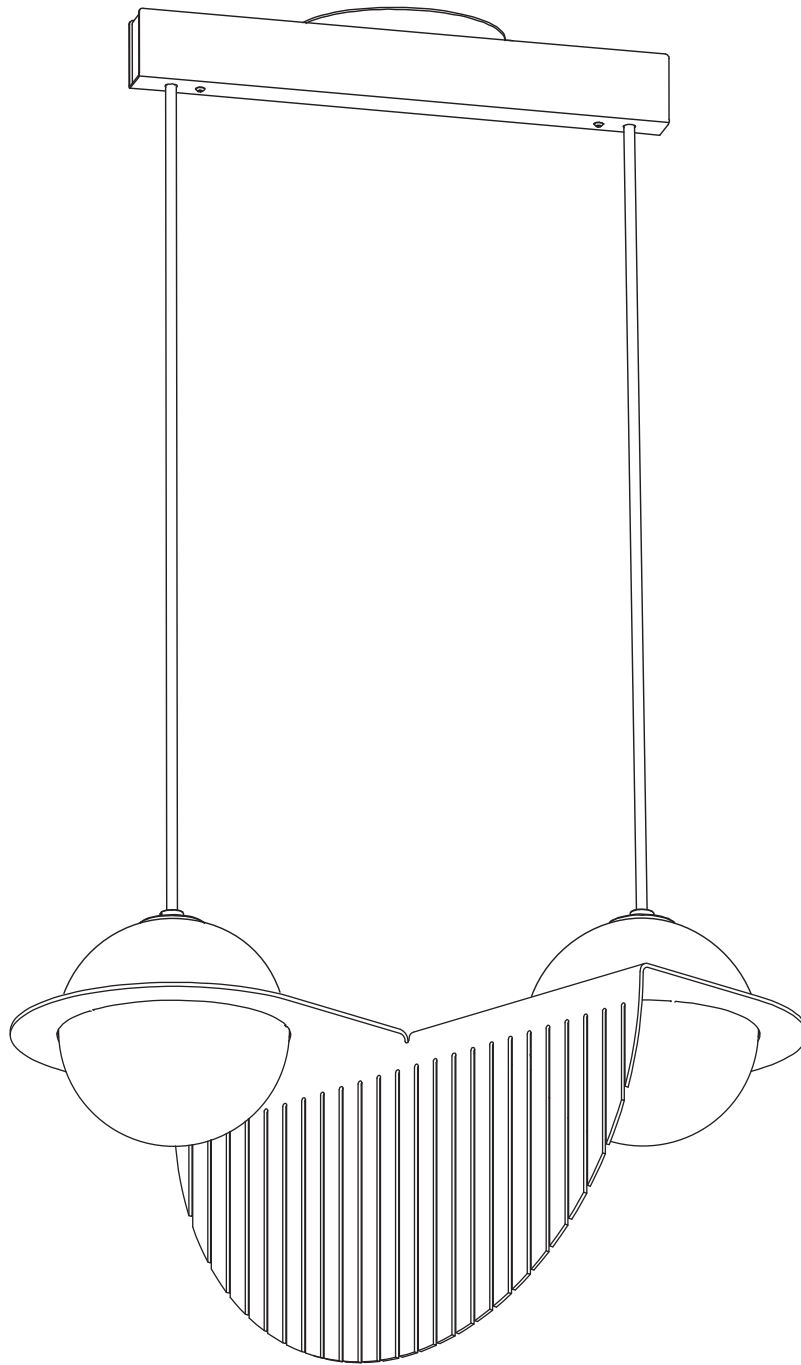

lambert&fils