

LAURENT 09

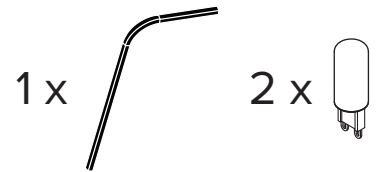

- To be installed by an electrician to an electrical box
- Use appropriate screws and anchors where necessary
- Wear enclosed gloves when handling lamp
- Handle materials with care. Please consult lamp maintenance sheet on our web site
- Should be used exclusively as a lamp and not as a shelving, display or hanging unit

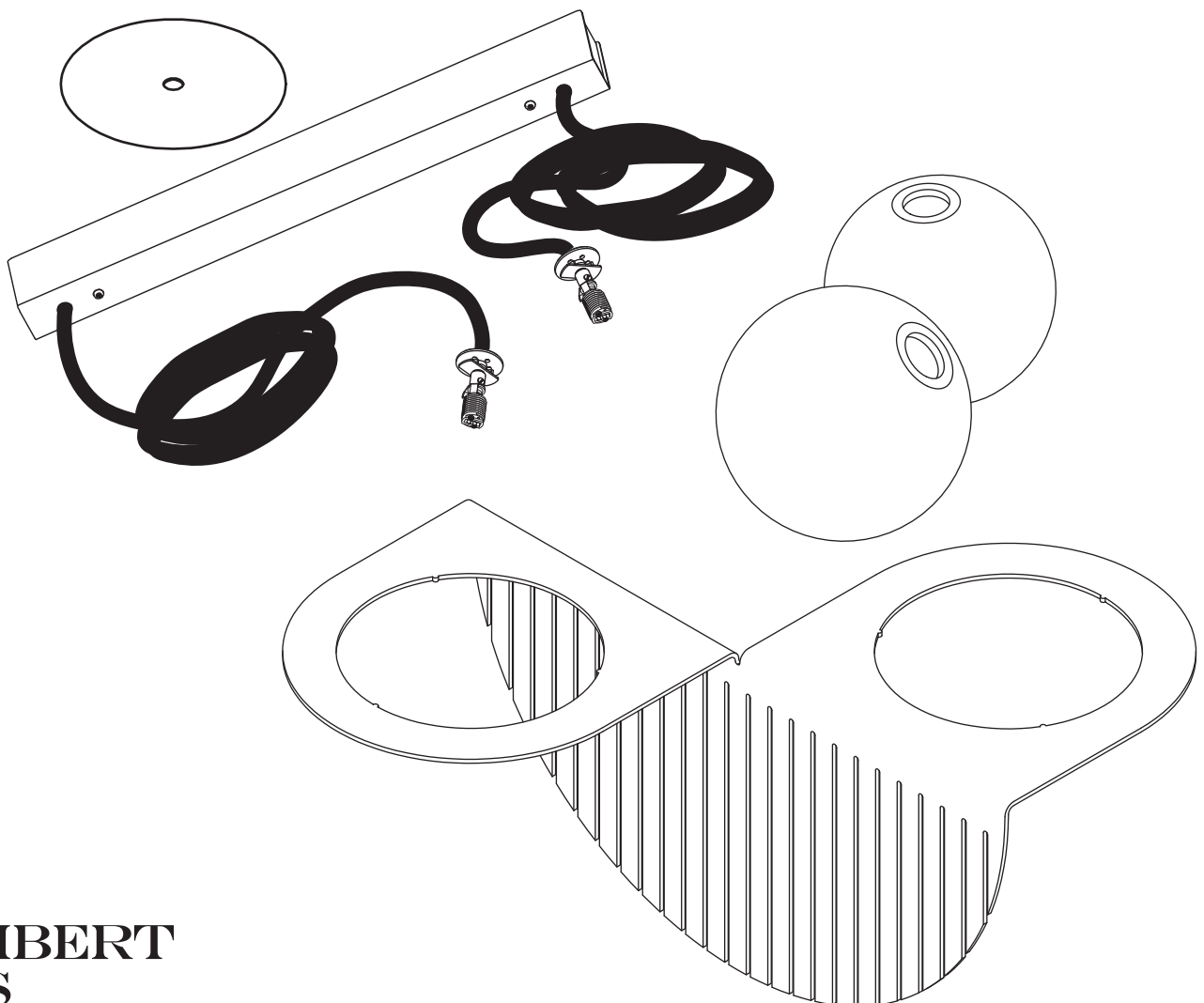
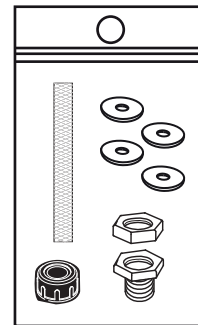

1

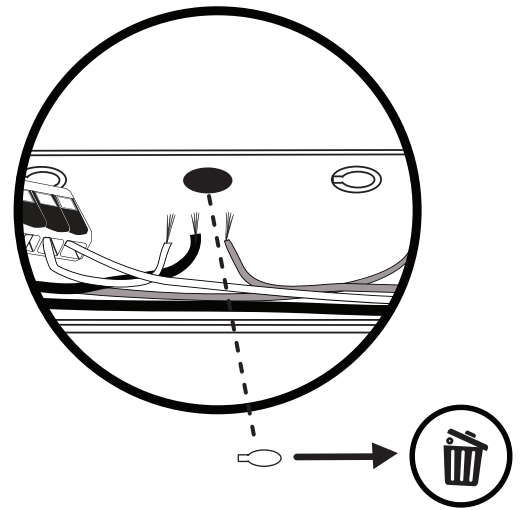
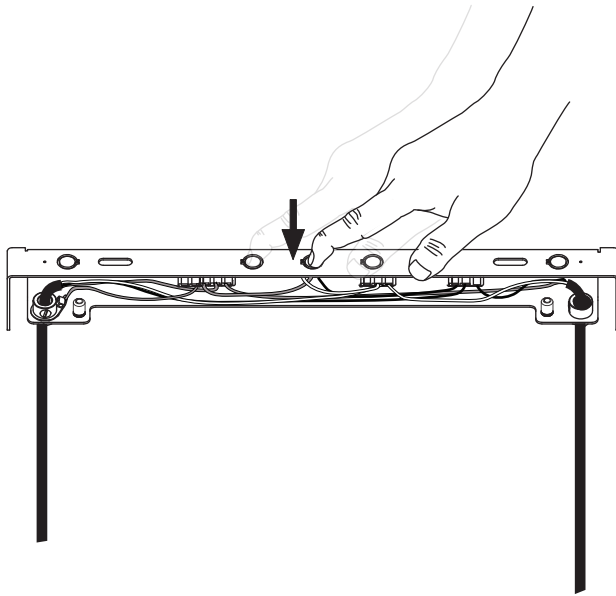

Knockout selected hole depending on desired electrical box alignment.

2

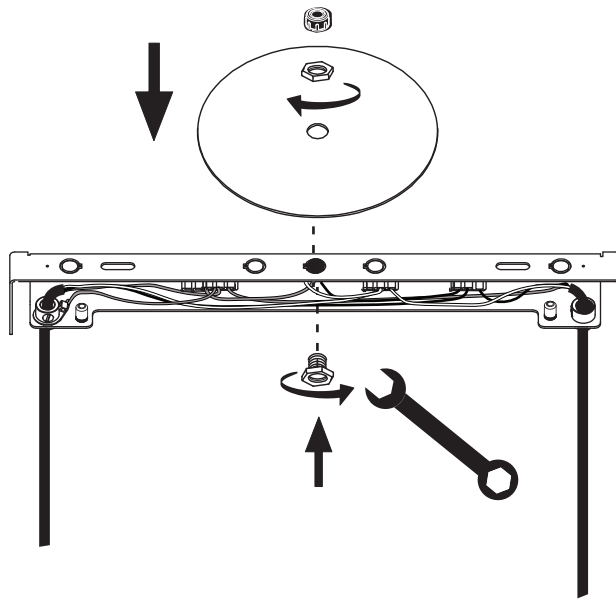

3

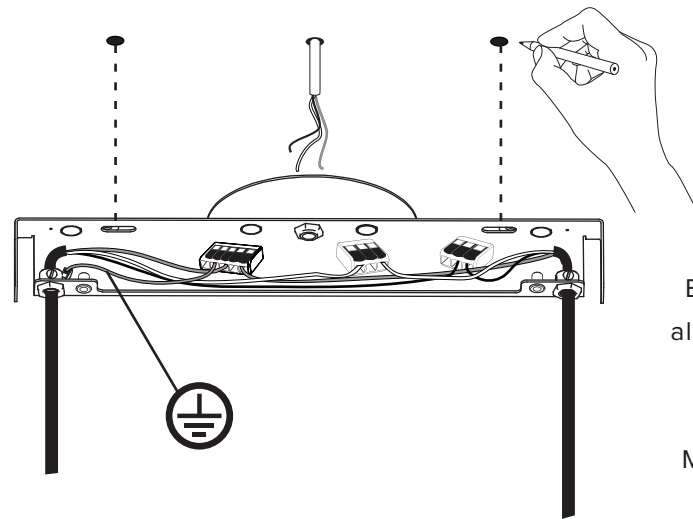

Before marking your anchor locations, align the ceiling bracket with the center of your junction box.

Make sure to use appropriate anchors for ceiling material.

4

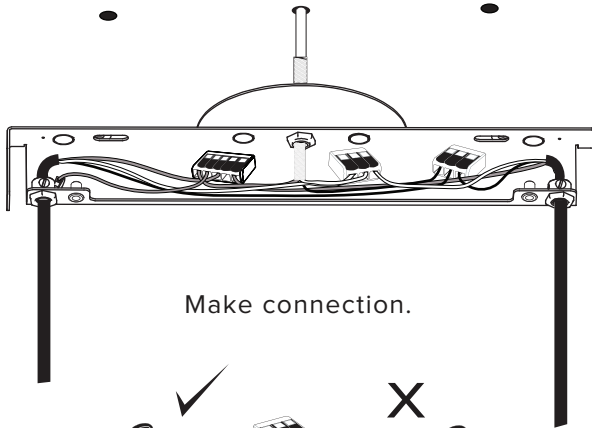

6mm

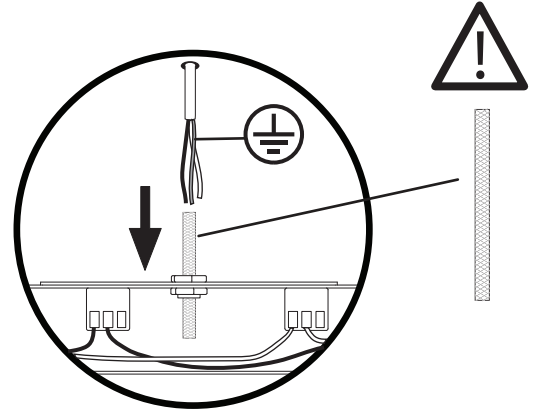
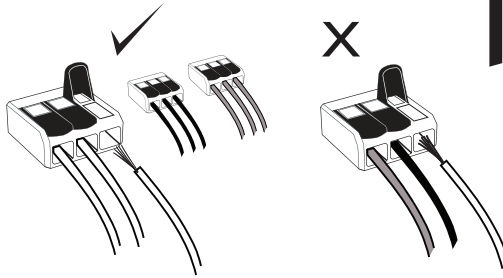

Insert anti-abrasive heat sleeve before making your connection.

5

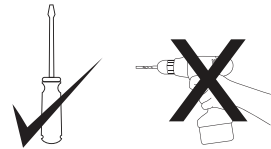
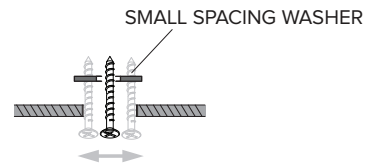
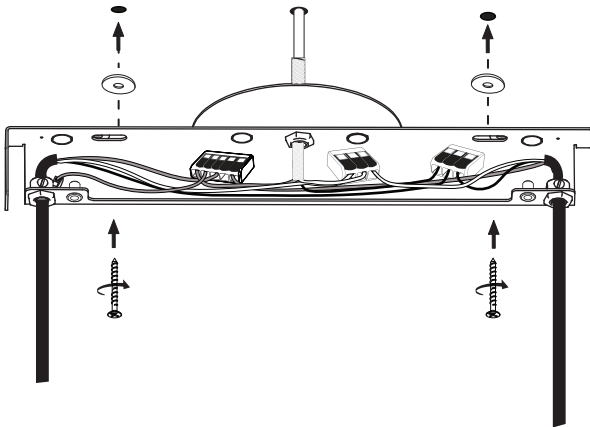

Avoid scuffing wires during this operation.

6

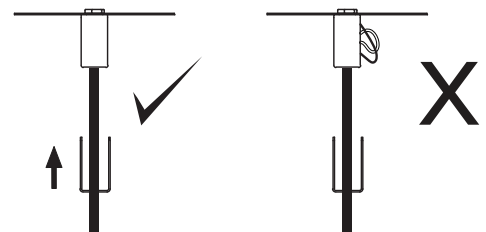
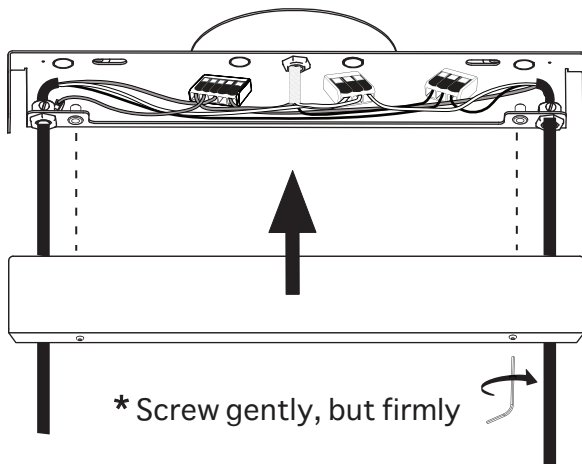

Ensure no wires are clipped or pinched during this operation.

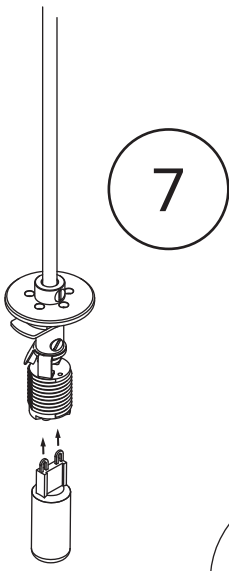

7

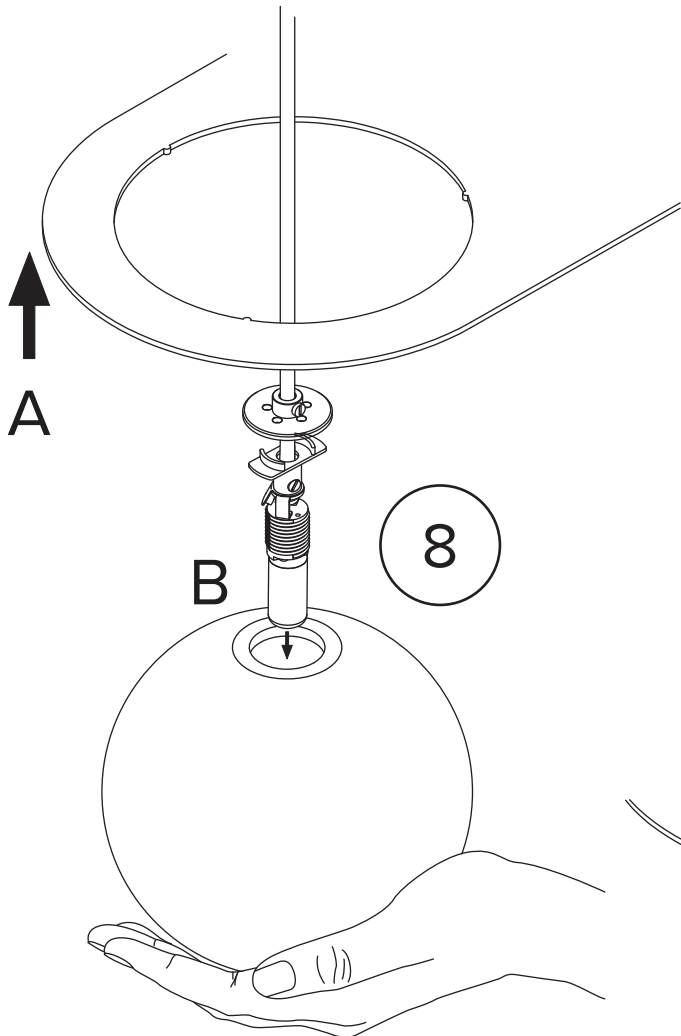

8

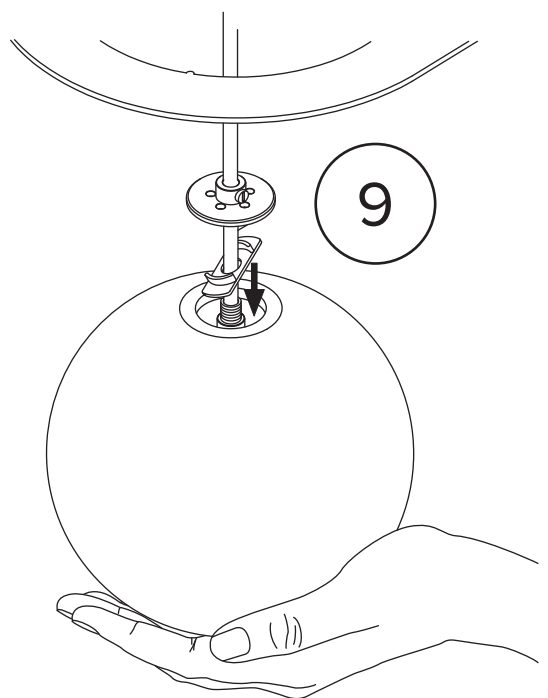

9

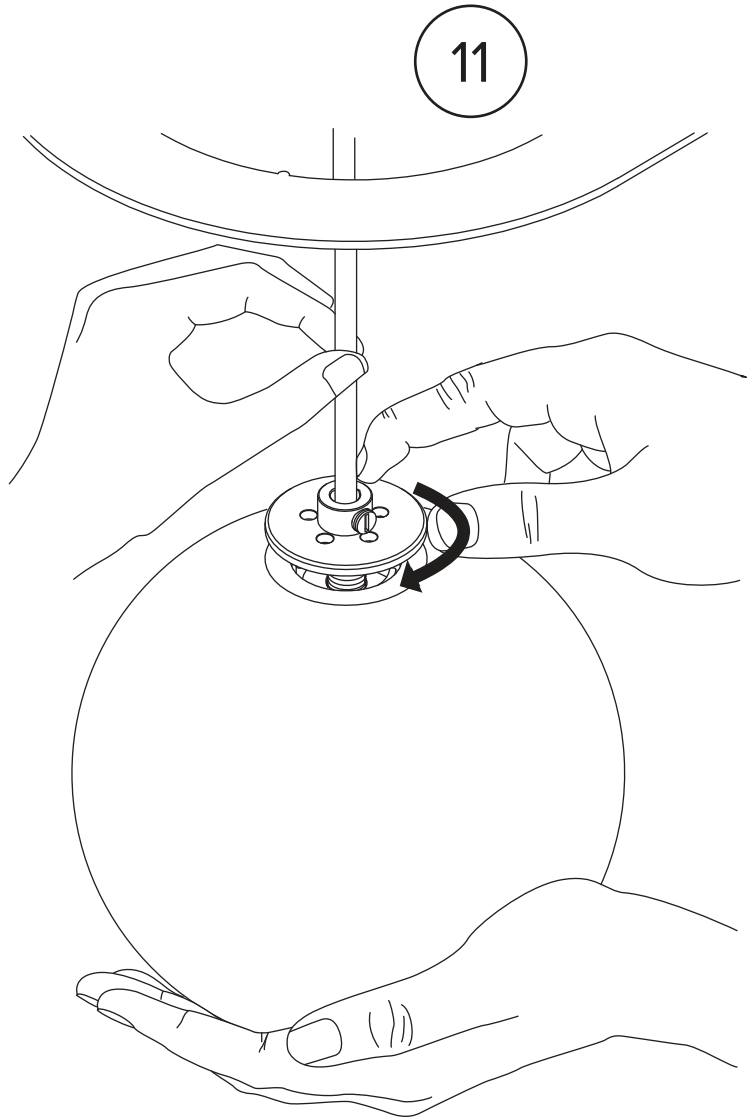
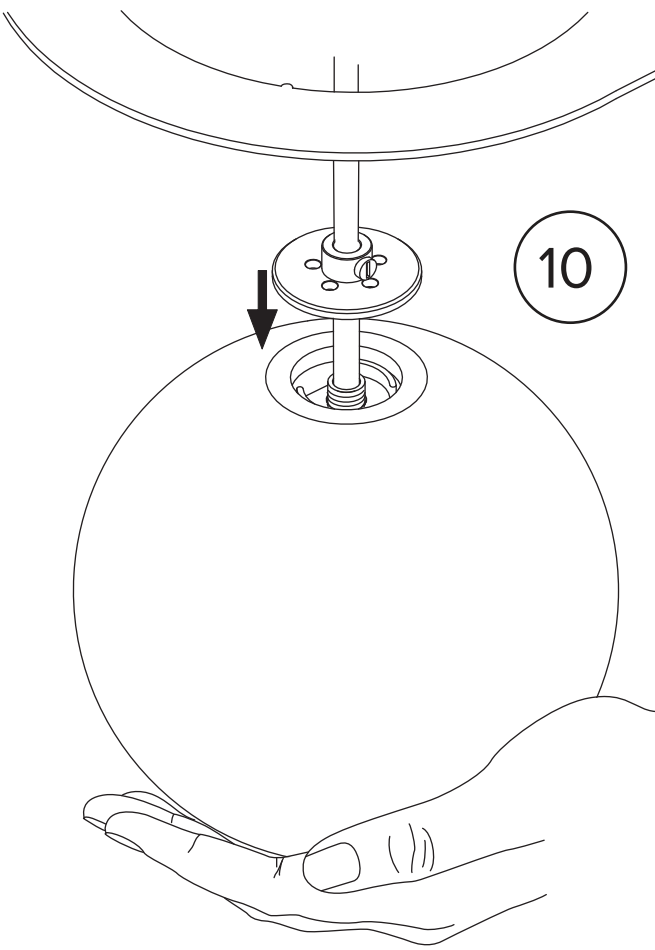

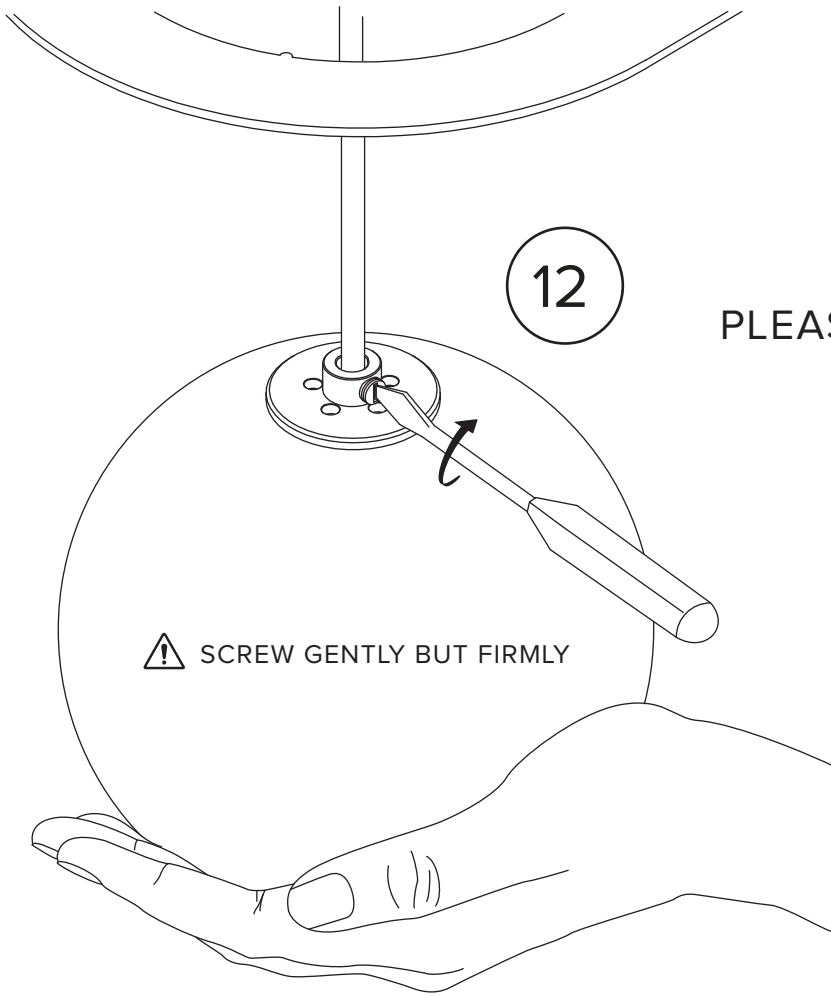

* To ensure safety,
PLEASE FOLLOW THESE STEPS
CAREFULLY

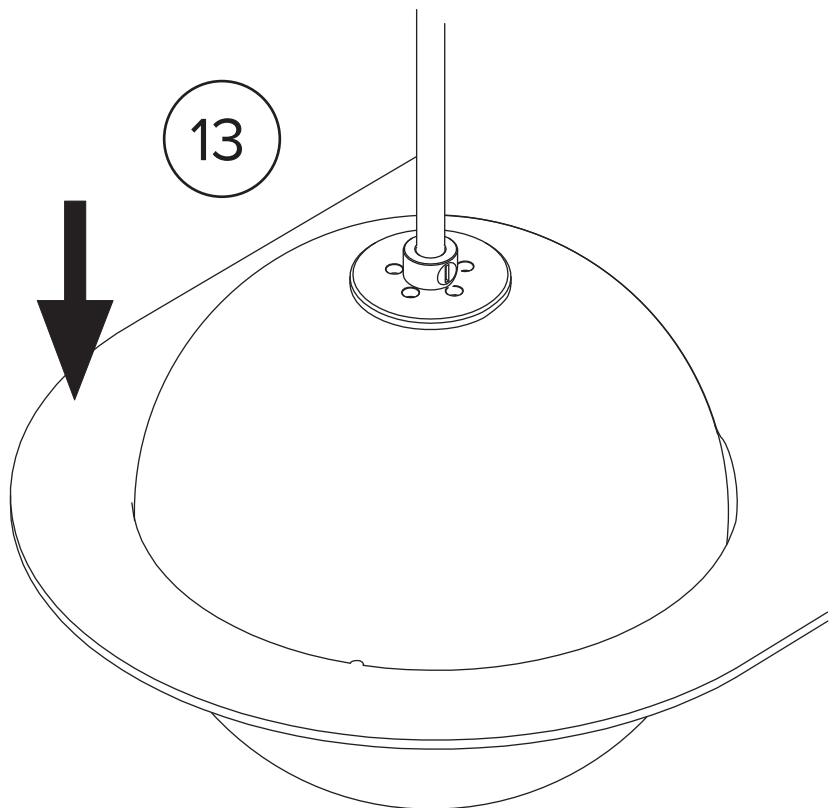

14

Make sure the globes are level by micro-adjusting the wire lengths.

SCREW GENTLY BUT FIRMLY

